

Каталог продукции ELK MOTOR

По вопросам продаж и поддержки обращайтесь:

Алматы (727)345-47-04
Ангарск (3955)60-70-56
Архангельск (8182)63-90-72
Астрахань (8512)99-46-04
Барнаул (3852)73-04-60
Белгород (4722)40-23-64
Благовещенск (4162)22-76-07
Брянск (4832)59-03-52
Владивосток (423)249-28-31
Владикавказ (8672)28-90-48
Владимир (4922)49-43-18
Волгоград (844)278-03-48
Вологда (8172)26-41-59
Воронеж (473)204-51-73
Екатеринбург (343)384-55-89

Иваново (4932)77-34-06
Ижевск (3412)26-03-58
Иркутск (395)279-98-46
Казань (843)206-01-48
Калининград (4012)72-03-81
Калуга (4842)92-23-67
Кемерово (3842)65-04-62
Киров (8332)68-02-04
Коломна (4966)23-41-49
Кострома (4942)77-07-48
Краснодар (861)203-40-90
Красноярск (391)204-63-61
Курск (4712)77-13-04
Курган (3522)50-90-47
Липецк (4742)52-20-81

Магнитогорск (3519)55-03-13
Москва (495)268-04-70
Мурманск (8152)59-64-93
Набережные Челны (8552)20-53-41
Нижний Новгород (831)429-08-12
Новокузнецк (3843)20-46-81
Ноябрьск (3496)41-32-12
Новосибирск (383)227-86-73
Омск (3812)21-46-40
Орел (4862)44-53-42
Оренбург (3532)37-68-04
Пенза (8412)22-31-16
Петрозаводск (8142)55-98-37
Псков (8112)59-10-37
Пермь (342)205-81-47

Ростов-на-Дону (863)308-18-15
Рязань (4912)46-61-64
Самара (846)206-03-16
Санкт-Петербург (812)309-46-40
Саратов (845)249-38-78
Севастополь (8692)22-31-93
Саранск (8342)22-96-24
Симферополь (3652)67-13-56
Смоленск (4812)29-41-54
Сочи (862)225-72-31
Ставрополь (8652)20-65-13
Сургут (3462)77-98-35
Сыктывкар (8212)25-95-17
Тамбов (4752)50-40-97
Тверь (4822)63-31-35

Тольятти (8482)63-91-07
Томск (3822)98-41-53
Тула (4872)33-79-87
Тюмень (3452)66-21-18
Ульяновск (8422)24-23-59
Улан-Удэ (3012)59-97-51
Уфа (347)229-48-12
Хабаровск (4212)92-98-04
Чебоксары (8352)28-53-07
Челябинск (351)202-03-61
Череповец (8202)49-02-64
Чита (3022)38-34-83
Якутск (4112)23-90-97
Ярославль (4852)69-52-93

Россия +7(495)268-04-70

Казахстан +7(727)345-47-04

Беларусь +(375)257-127-884

Узбекистан +998(71)205-18-59

Киргизия +996(312)96-26-47

эл.почта: eko@nt-rt.ru || сайт: <https://elk-motor.nt-rt.ru/>





ELK Motor is on a mission to establish itself as a global brand by embracing its core values of environmental and human sensitivity, innovation, and technology. This mission is driven by a commitment to sustainability and the careful consideration of limited global resources. ELK Motor strives to achieve this by delivering eco-friendly, innovative, competitive, and highly efficient products.

Founded by the major shareholders of Yılmaz Redüktör A.Ş., ELK Motor was established in the Çerkezköy Organized Industrial Zone to expand their product line. The company operates on a 135,000 m² open area, with 50,000 m² of enclosed space, dedicated to the production of electric motors ranging from IEC 63 to 315 frame sizes.

Our product portfolio includes three-phase motors in the IEC 63 to 315 frame size range, single-phase motors in the IEC 63 to 90 frame size range (offering options with run or run + start capacitor), Zone 2/22 Exproof motors in the IEC 63 to 315 frame size, and Zone 1/21 Exproof motors in the IEC 160 frame size, with plans to expand this range soon.

All motor series are designed in accordance with European standards and are available in IE2, IE3, and IE4 efficiency classes, ensuring they meet customer requirements. Moreover, our motors were initially designed to meet the IE3 efficiency class, enabling a seamless transition from IE2 to IE3 without altering the mechanical dimensions, providing users with consistent performance and compatibility.

In addition to our standard motors, we also offer custom-designed motors tailored to meet specific performance and compatibility needs of our customers.

Produced entirely at our Çerkezköy factory, ELK Motors undergo a comprehensive production process that includes engineering, machining, casting, sheet metal work, and motor winding. Each motor is subjected to 100% final inspection and testing to ensure the highest levels of quality and performance upon delivery.

Finally, ELK Motor adheres to strict quality management systems and holds the necessary product certifications to meet customer demands. Our quality system is certified to ISO 9001, and our products carry UL certification.



CONTENTS

| | |
|--|----|
| THREE PHASE MOTORS | 6 |
| Technical Information | 6 |
| IEC/EN/UL Compatibility | 7 |
| Electrical Construction | 8 |
| Electrical Connections | 8 |
| Motors at 60Hz Network | 9 |
| Operating Motors with Variable Speed Drives | 9 |
| Operating Motors in Various Environmental Conditions | 9 |
| Duty Cycle | 10 |
| Winding Insulation / Temperature Rise Classes | 12 |
| Protection Classes | 12 |
| Vibration Classes | 13 |
| Cooling Classes | 14 |
| Mechanical Construction | 15 |
| Construction Types | 16 |
| Bearings | 18 |
| Lubrication | 19 |
| Radial Loads | 22 |
| Axial Loads | 24 |
| Product Type Codes of Three-Phase Motors | 28 |
| | |
| THREE-PHASE MOTORS | 29 |
| IE2 Motors | 29 |
| IE3 Motors | 31 |
| IE4 Motors | 36 |
| Dimensions | 40 |
| Motor Nameplate Description | 44 |
| Three-Phase Motors Spare Parts | 45 |
| | |
| SINGE-PHASE MOTORS | 46 |
| Technical Information | 46 |
| Electrical Construction | 47 |
| Electrical Connections | 47 |
| Mechanical Construction | 48 |
| Bearings | 48 |
| Radial Loads | 49 |
| Axial Loads | 49 |
| Product Type Codes of Single-Phase Motors | 51 |
| | |
| SINLGE-PHASE IE2 MOTORS | 52 |
| IE2 Motors with Run Capacitor | 53 |
| IE2 Motors with Run + Start Capacitor | 54 |
| Dimensions | 55 |
| Motor Nameplate Description | 62 |
| Single-Phase Motors Spare Parts | 63 |

CONTENTS

| | |
|--|----|
| EXPROOF MOTORS | 65 |
| Technical Information | 65 |
| Overview | 66 |
| IEC/EN/UL Compatibility | 66 |
| Explosion Protection Directive | 67 |
| Electrical Construction | 68 |
| Electrical Connections | 68 |
| Winding Insulation | 69 |
| Protection Classes | 69 |
| Mechanical Construction | 70 |
| Construction Types | 71 |
| Bearings | 73 |
| Radial Loads | 74 |
| Axial Loads | 76 |
| Product Type Codes of Exproof Motors | 79 |
| ZONE 2/22 EXPROOF MOTORS | 80 |
| IE2 Motors | 80 |
| IE3 Motors | 82 |
| IE4 Motors | 86 |
| Dimensions | 90 |
| Motor Nameplate Description | 94 |
| Zone 2-22 Exproof Motors Spare Parts | 95 |
| ACCESSORIES AND COMPONENTS | 96 |
| PTC Thermistor and Thermal Switch | 97 |
| Anti-Condensation Space Heater and Drainage | 97 |
| NDE Shaft and Canopy | 97 |
| Brake, Hand Release, Separately Driven Fan, Encoder and Backstop | 98 |
| NOTES | 99 |

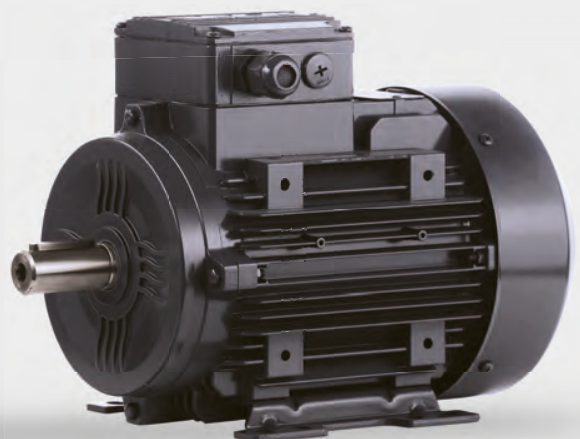

THREE-PHASE MOTORS



**Technical
Information**

IEC/EN/UL Compatibility

Our standard products are designed, manufactured, and tested in full compliance with the standards listed below.

| | |
|----------------|--|
| IEC 60034-1 | Rating and Performance |
| IEC 60034-2-1 | Methods for Determining Losses and Efficiency |
| IEC 60034-5 | Classification of Degrees of Protection |
| IEC 60034-6 | Methods of Cooling |
| IEC 60034-7 | Symbols of Construction and Mounting Arrangements |
| IEC 60034-8 | Terminal Markings and Direction of Rotation |
| IEC 60034-9 | Noise Limits |
| IEC 60034-11 | Built-in Thermal Protection |
| IEC 60034-14 | Vibration Limits |
| IEC 60034-18-1 | Functional Evaluation of Insulation Systems |
| IEC 60034-30 | Efficiency Classes (IE Code) |
| IEC 60038 | Standard Voltages |
| EN 50347 | Dimensions and Output Powers for Electrical Machines |

| | |
|--------------|-------------------------------|
| EN 55014-1 | Electromagnetic Compatibility |
| EN 61000-3-2 | |
| EN 61000-3-3 | |

| | |
|-------------------|---|
| UL1004-1 | Rotating Electrical Machines – General Requirements |
| CSA C22.2 No. 100 | Motors and Generators |



All electric motors featuring the logo on their nameplate are UL certified and manufactured under file number E496161 in accordance with UL 1004-1 and CSA C22.2 No. 100 standards.

Our products may deviate from the nominal values specified in our catalog by the amounts or percentages permitted under IEC 60034-1, as outlined below.

| | |
|---|---|
| Motor Speed (n) | $\Delta n = \pm 20\% (n_s - n_N), P_N \geq 1 \text{ kW}$ $\Delta n = \pm 30\% (n_s - n_N), P_N < 1 \text{ kW}$ |
| Efficiency %(η) | $\Delta \eta = -15\% (100 - \eta_N)$ |
| Power factor (ϕ) | $\text{Cos} \phi = -1/6 (1 - \text{Cos} \phi)$ |
| Locked rotor current (I_{LN}) | $\Delta (I_{LN}) = +20\% (I_{LN})$ |
| Starting torque (M_L/M_N) | min. $(M_L/M_N) = -15\% (M_L/M_N)$ max. $(M_L/M_N) = +25\% (M_L/M_N)$ |
| Breakdown torque (M_K/M_N) | $(M_K/M_N) = -10\% (M_K/M_N)$ |
| Torque of inertia (J) [kgm²] | $\Delta J = \pm 10\% J$ |
| Sound pressure level (L_{PA}) [dB(A)] | $L_{PA} = +3 \text{ dB (A)}$ |

Electrical Construction

Our standard motors have an F class (155°C) electrical insulation system. However, all standard motors in our product range operate within B class temperature rise limits. This ensures that the provided temperature class has a safety margin, allowing our motors to operate under more demanding conditions than specified or to have a longer service life under normal conditions. Motors with H class insulation can be manufactured according to customer requirements.

Electrical Connections

| Cable Gland and Blind Cap | | | | | | | | | | | | | | |
|---------------------------|---------|---------|-----|---------|-----|-----|-------------|-----|----------------------------|-----|----------------------------|-----|-------------|-----|
| Frame Size | 063 | 071 | 080 | 090 | 100 | 112 | 132 | 160 | 180 | 200 | 225 | 250 | 280 | 315 |
| Cable Glands | M16x1,5 | M20x1,5 | | M25x1,5 | | | 2 x M32x1,5 | | 1 x M12x1,5 2 x M40x1,5 | | 1 x M12x1,5 2 x M50x1,5 | | 2 x M63x1,5 | |
| Blind Cap | M16x1,5 | | | M25x1,5 | | | - | | - | | - | | - | |

| Terminal Connections | | | | | | | | | | | | | | |
|----------------------|-----|-----|-----|-----|-----|-----|-----|-----|-----|-----|-----|-----|-----|-----|
| Frame Size | 063 | 071 | 080 | 090 | 100 | 112 | 132 | 160 | 180 | 200 | 225 | 250 | 280 | 315 |
| Terminal Size | M4 | | | | M5 | | | M6 | | | M8 | M10 | | M16 |

The motors shall be connected in star or delta according to rated voltage given in their nameplate and the network voltage that they will be connected. For phase to phase 400V supply the motors with 230/400V nameplate values shall be connected in star and the motors with 400/690V nameplate values shall be connected in delta. The connection types given below should be applied for single phase motors, depending on the direction of rotation.

Terminal Connections for Three-Phase Motors

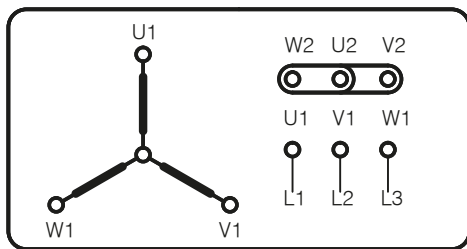

Y Star Connection
Clockwise

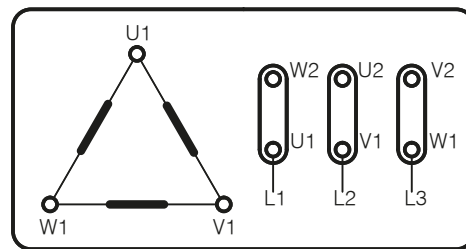

Δ Delta Connection
Clockwise

Standard ELK Motors are manufactured to rotate in a clockwise direction. To change the rotation direction, the positions of any two phases on the terminal can be swapped. For an example, please refer to the schematic below.

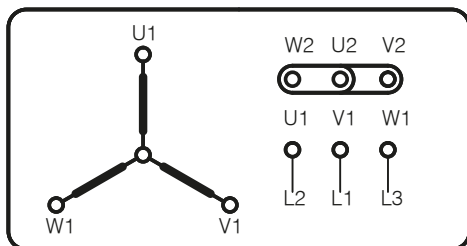

Y Star Connection
Counter-Clockwise

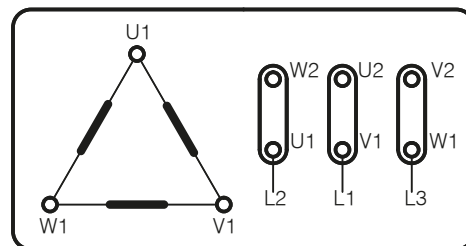

Δ Delta Connection
Counter-Clockwise

Motors at 60Hz Network

Standard ELK Motors that have been manufactured for 50 Hz power supply can be used at 60Hz network. The ratios given below indicate changes in the given rated values.

| 50 Hz Rated Voltage | 60 Hz Rated Voltage | Rated Speed | Rated Power | Rated Torque | Rated Current | Starting Torque | Break Down Torque | Starting Current |
|---------------------|---------------------|-------------|-------------|--------------|---------------|-----------------|-------------------|------------------|
| 230V | 220V | 1.193 | 1 | 0.84 | 0.97 | 0.77 | 0.8 | 0.8 |
| 400V | 380V | 1.193 | 1 | 0.84 | 0.97 | 0.77 | 0.8 | 0.8 |
| 400V | 440V | 1.20 | 1.16 | 0.97 | 0.98 | 0.87 | 0.9 | 0.9 |

Operating Motors with Variable Speed Drives

Standard ELK Motors are designed to be compatible with drives. When operated with an internal fan or a force cooling fan, the torque capacity of the motors is as shown in the frequency-torque curve below. An external force cooling fan must be used when operating at low speed for prolonged time. The power cables between the VSD and the motor should be kept as short as possible.

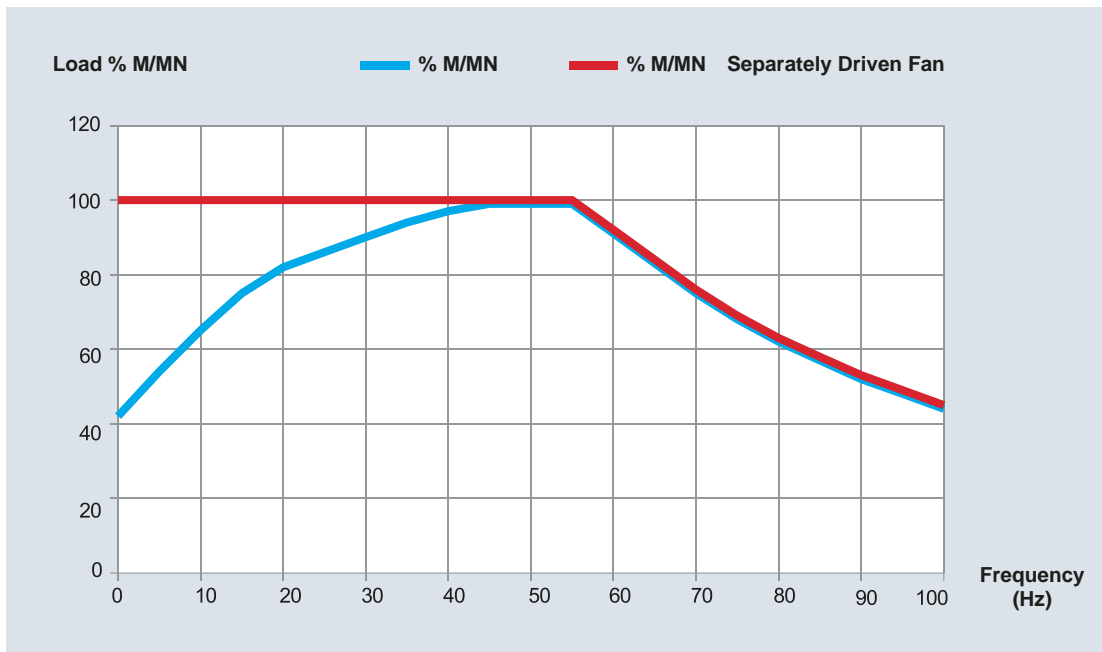

Operating Motors in Various Environmental Conditions

The performance values of our motors specified in the catalogue are valid for use at an ambient temperature of 40°C and altitudes up to 1000 meters, as specified in IEC 60034-1. For other ambient temperatures, the output power of our motors will vary according to the ratios given in the table below.

| Ambient Temperature | <30 °C | 35 °C | 40 °C | 45 °C | 50 °C | 55 °C | 60 °C |
|---------------------|--------|-------|-------|-------|-------|-------|-------|
| %Power Ratio | 105 | 102 | 100 | 97 | 93 | 87 | 82 |

Operating Motors in Various Environmental Conditions

| Nominal Power Changes According to Altitude | | | | | | | |
|---|--------------|--------------|--------------|--------------|--------------|--------------|--------------|
| Altitude | Up to 1000 m | Up to 1500 m | Up to 2000 m | Up to 2500 m | Up to 3000 m | Up to 3500 m | Up to 4000 m |
| %Power Ratio | 100 | 98 | 95 | 91 | 87 | 83 | 78 |

Duty Cycle

Our standard motors have an S1 Duty Cycle, and the types of operation specified in IEC 60034-1 are listed below:

| | | | | | |
|---|------------------------|--|---|------------------------|--|
| S1 | Continuous Duty | | S2 | Short-Time Duty | |
| <p>The motor operates at a constant load long enough to reach thermal equilibrium</p> | | | <p>The motor runs at a constant load for a limited time, shorter than the time needed to reach thermal equilibrium, followed by a rest period. In general, 10, 30, 60, and 90-minute operating times are recommended.</p> | | |

| | | | | | |
|---|-----------------------------------|--|--|---|--|
| S3 | Intermittent Periodic Duty | | S4 | Intermittent Periodic Duty with Starting | |
| <p>The motor operates in a sequence of identical cycles, each consisting of a period of constant load and a rest period. The rest period is long enough to prevent the motor from reaching thermal equilibrium. The operating period duration is typically 10 minutes, with relative operating times of 15%, 25%, 40%, and 60%.</p> | | | <p>Similar to S3, but includes a significant starting period where the motor starts with a load, followed by a period of constant load and a rest period. In general, 10, 30, 60, and 90-minute operating times are recommended.</p> | | |

Duty Cycle

| | | | | |
|---|--|---|---|--|
| <p>S5</p> | <p>Intermittent Periodic Duty with Electrical Braking</p> | | <p>S6</p> <p>Continuous Operation Periodic Duty</p> | |
| <p>The motor operates in a sequence of identical duty cycles, each cycle consisting of a starting time, a time of operation at constant load, a time of electric braking and a time de-energized and at a rest.</p> | | <p>The motor operates in a sequence of identical cycles, each consisting of a period of constant load followed by a period of no load. There is no rest period, so motor should be operated in such a way that it does not reach thermal equilibrium at full load. Typically, relative operating times of 5%, 25%, 40%, and 60% are used.</p> | | |

| | | | | |
|---|--|--|--|--|
| <p>S7</p> | <p>Continuous Operation Periodic Duty with Electrical Braking</p> | | <p>S8</p> <p>Continuous Operation Periodic Duty with Load Variations</p> | |
| <p>This is a sequence of identical duty cycles, each consisting of a period of start, a period of operation at constant load and a period of electric braking. Operating periods are designed in a way that the motor does not reach thermal equilibrium. There is no rest and de-energizing periods.</p> | | <p>This is a sequence of identical duty cycles, each consisting of a period of operation at constant load, corresponding to a determined speed of rotation, followed immediately by a period of operation at another load, corresponding to another speed of rotation. There is no rest and de-energizing period</p> | | |

| | | |
|---|---------------------------------|--|
| <p>S9</p> | <p>Non-periodic Duty</p> | |
| <p>The motor operates under varying loads and speeds, which can be non-periodic. It includes overloads beyond the rated values.</p> | | |

Winding Insulation / Temperature Rise Classes

All standard motors in the ELK Motor range have F (155 °C) class electrical insulation system. However, by means of its superior design features, the temperature rise of all standard motors remain within the Class B temperature rise limits when operating under rated conditions. Depending on the safety margin of the temperature rise class provided, our motors can provide 15% higher rated output power with a service factor of 1.15 (SF).

INSULATION CLASS

Maximum Winding Temperature

Tolerance

Limits of Winding Temperature

Ambient Temperature

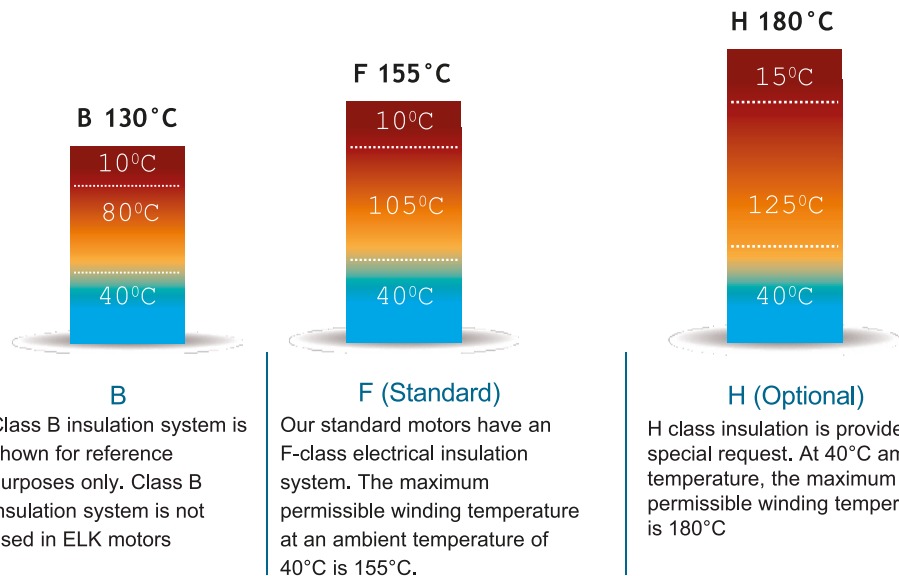

B
Class B insulation system is shown for reference purposes only. Class B insulation system is not used in ELK motors

F (Standard)
Our standard motors have an F-class electrical insulation system. The maximum permissible winding temperature at an ambient temperature of 40°C is 155°C.

H (Optional)
H class insulation is provided on special request. At 40°C ambient temperature, the maximum permissible winding temperature is 180°C

Protection Classes

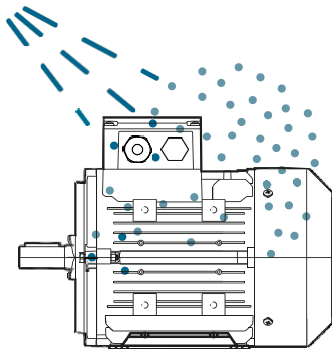

IP55 (Standard)

Ingress of dust in amounts that could be harmful has been prevented, and ingress of water in amounts that could be harmful is prevented in case of water spray from any direction.

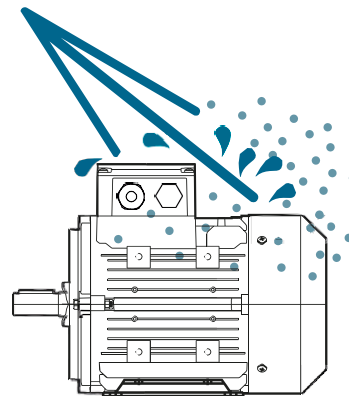

IP56

Ingress of dust in amounts that could be harmful has been prevented, and ingress of water in amounts that could be harmful is prevented in case of pressurized water spray from any direction.

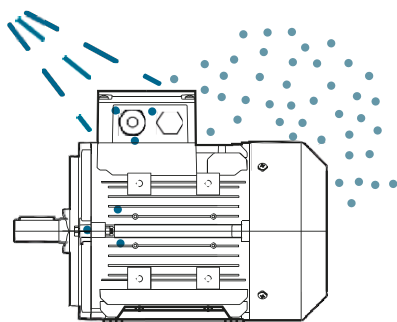

IP65

Ingress of dust is completely prevented, and ingress of water in amounts that could be harmful is prevented in case of water spray from any direction.

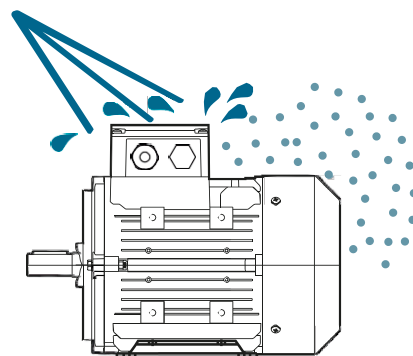

IP66

Ingress of dust is completely prevented, and ingress of water in amounts that could be harmful is prevented in case of pressurized water spray from any direction..

Protection Classes

It is the classification of the protection degrees provided by the motor's external enclosure against Mechanical / Physical impacts. ELK Motors provide standard protection with an IK08 rating.

| Protection Class | Impact Energy (Joule) |
|------------------|------------------------|
| IK00 | No Protection |
| IK01 | 0,14 |
| IK02 | 0,2 |
| IK03 | 0,35 |
| IK04 | 0,5 |
| IK05 | 0,7 |
| IK06 | 1 |
| IK07 | 2 |
| IK08 | 5 (ELK Motor Standard) |
| IK09 | 10 |
| IK10 | 20 |

Vibration Classes

In ELK motors, shaft balancing and vibration measurements are performed with a half key, and vibration levels are detected. Based on the IEC 60034-14 standard, we guarantee an A-class (free suspension) vibration level for our motors. The declared maximum vibration values are as shown in the table.

| Vibration Grade | Shaft Height (mm) | 56 ≤ H ≤ 132 | | | 132 < H ≤ 280 | | | H > 280 | | |
|-----------------|-------------------|--------------|--------|---------------------|---------------|--------|---------------------|--------------|--------|---------------------|
| | Mounting | Displacement | Speed | Acceleration | Displacement | Speed | Acceleration | Displacement | Speed | Acceleration |
| | | (mm) | (mm/s) | (m/s ²) | (mm) | (mm/s) | (m/s ²) | (mm) | (mm/s) | (m/s ²) |
| A | Freely Suspended | 25 | 1,6 | 2,5 | 35 | 2,2 | 3,5 | 45 | 2,8 | 4,4 |
| | Rigidly Mounted | 21 | 1,3 | 2 | 29 | 1,8 | 2,8 | 37 | 2,3 | 3,6 |
| B | Freely Suspended | 11 | 0,7 | 1,1 | 18 | 1,1 | 1,7 | 29 | 1,8 | 2,8 |
| | Rigidly Mounted | - | - | - | 14 | 0,9 | 1,4 | 24 | 1,5 | 2,4 |

Cooling Classes

ELK Motors can be produced with the following cooling options in accordance with the IEC 60034-6 standard. Our standard motors are manufactured using the IC411 method.

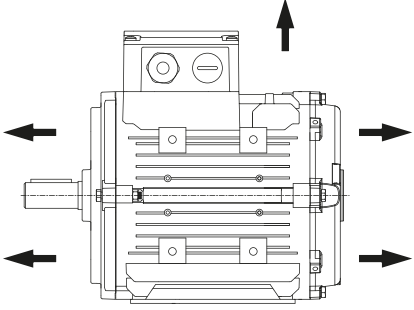
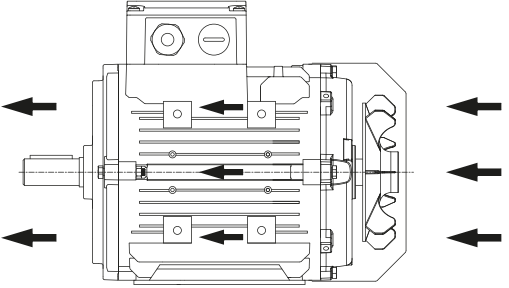
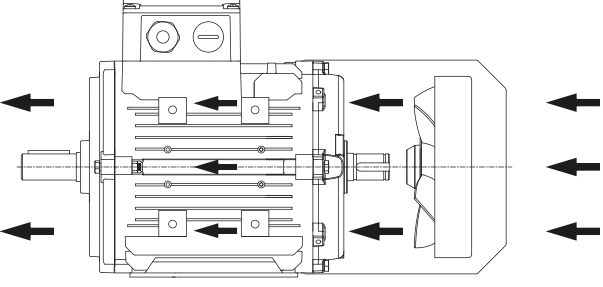
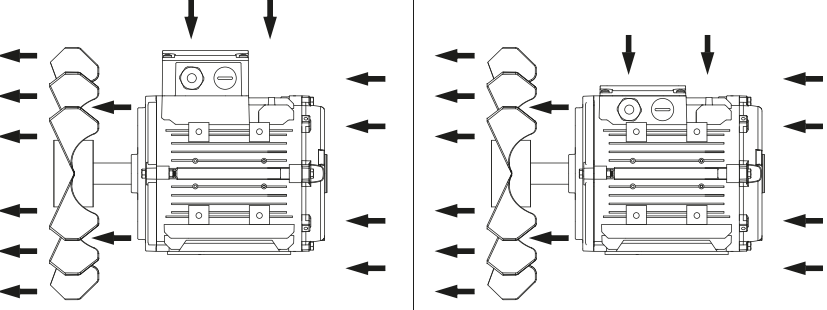
| | |
|--------------|--|
| IC410 - TENV |  |
| IC411 - TEFC |  |
| IC416 - TEBC |  |
| IC418 - TEAO |  |

Mechanical Construction

ELK Motors feature a detachable foot structure in all frame sizes, on top of that, the foot can also be attached to three sides of the body. This allows users to easily configure the motor with the terminal box on the right, top, or left by changing the feet position. In standard motors, the terminal box is positioned on the top.

MOTOR SIZE 63-315

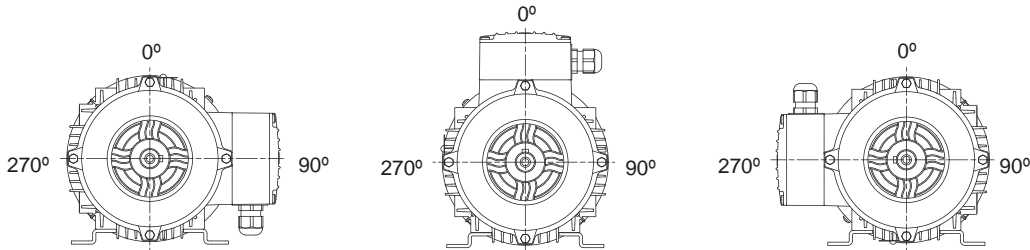

Additionally, due to the symmetric frame and foot structure of ELK Motors, the C dimension remains constant when the DE end-shield, NDE end-shield, and the shaft direction are changed. This allows the terminal box to be positioned closer to either the DE or NDE side (fan) side.

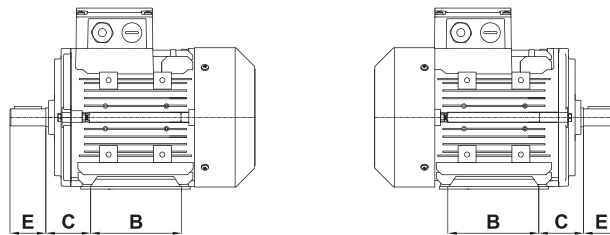

The materials used in our products are as specified below.

| Frame Size | Housing | End Shield DE | End Shield NDE | Terminal Box & Cover | Feet | Fan Cover | Fan |
|------------|-----------|---------------|----------------|----------------------|-------------|-------------|---------|
| 63 | Aluminum | Aluminum | Aluminum | Aluminum | Steel Sheet | Steel Sheet | Plastic |
| 71 | Aluminum | Aluminum | Aluminum | Aluminum | Steel Sheet | Steel Sheet | Plastic |
| 80 | Aluminum | Aluminum | Aluminum | Aluminum | Steel Sheet | Steel Sheet | Plastic |
| 90 | Aluminum | Aluminum | Aluminum | Aluminum | Steel Sheet | Steel Sheet | Plastic |
| 100 | Aluminum | Aluminum | Aluminum | Aluminum | Steel Sheet | Steel Sheet | Plastic |
| 112 | Aluminum | Aluminum | Aluminum | Aluminum | Steel Sheet | Steel Sheet | Plastic |
| 132 | Aluminum | Aluminum | Aluminum | Aluminum | Steel Sheet | Steel Sheet | Plastic |
| | Cast Iron | Cast Iron | Cast Iron | Cast Iron | Cast Iron | Steel Sheet | Plastic |
| 160 | Aluminum | Aluminum | Aluminum | Aluminum | Aluminum | Steel Sheet | Plastic |
| | Cast Iron | Cast Iron | Cast Iron | Cast Iron | Cast Iron | Steel Sheet | Plastic |
| 180 | Aluminum | Aluminum | Aluminum | Aluminum | Aluminum | Steel Sheet | Plastic |
| | Cast Iron | Cast Iron | Cast Iron | Cast Iron | Cast Iron | Steel Sheet | Plastic |
| 200 | Aluminum | Aluminum | Aluminum | Aluminum | Aluminum | Steel Sheet | Plastic |
| | Cast Iron | Cast Iron | Cast Iron | Cast Iron | Cast Iron | Steel Sheet | Plastic |
| 225 | Aluminum | Aluminum | Aluminum | Aluminum | Aluminum | Steel Sheet | Plastic |
| | Cast Iron | Cast Iron | Cast Iron | Cast Iron | Cast Iron | Steel Sheet | Plastic |
| 250 | Cast Iron | Cast Iron | Cast Iron | Cast Iron | Cast Iron | Steel Sheet | Plastic |
| 280 | Cast Iron | Cast Iron | Cast Iron | Cast Iron | Cast Iron | Steel Sheet | Plastic |
| 315 | Cast Iron | Cast Iron | Cast Iron | Cast Iron | Cast Iron | Steel Sheet | Plastic |

* Motors that do not have a symmetric frame structure are indicated in the efficiency tables.

Construction Types

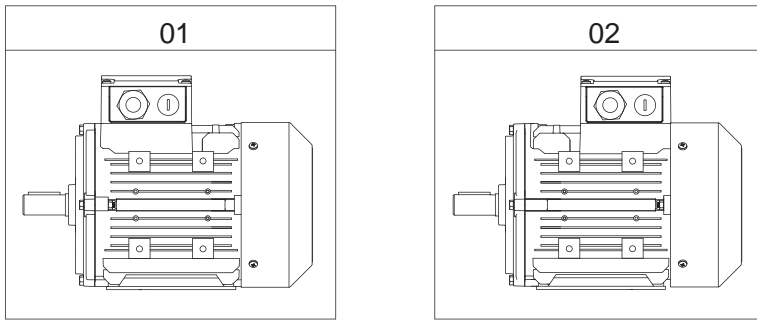

Standard ELK motors can be positioned with the terminal box on the drive side or the fan side. Depending on these options, the motor foot and flange orientation options are as shown in the table.

01: Terminal box on the drive side
 02: Terminal box on the fan side

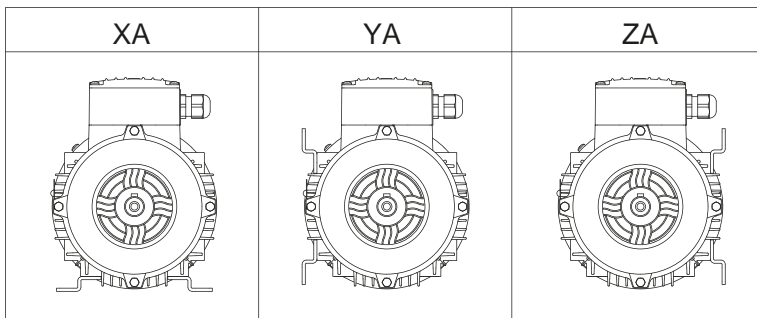

X: Feet on the ground when viewed from the drive side
 Y: Feet on the left when viewed from the drive side
 Z: Feet on the right when viewed from the drive side

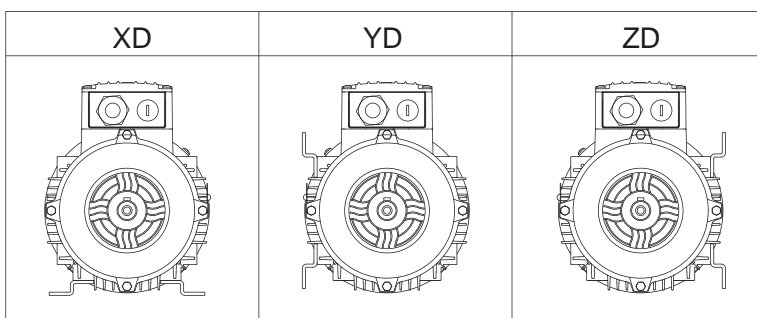
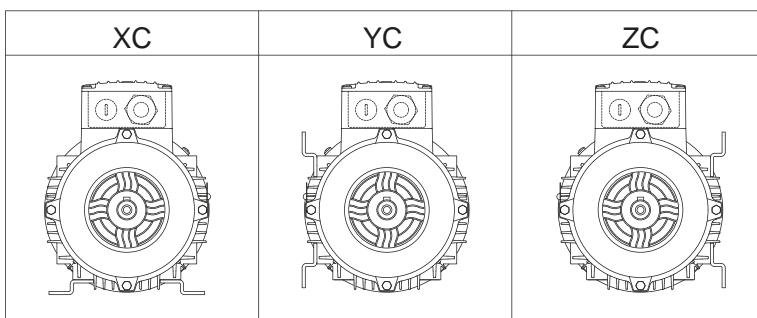
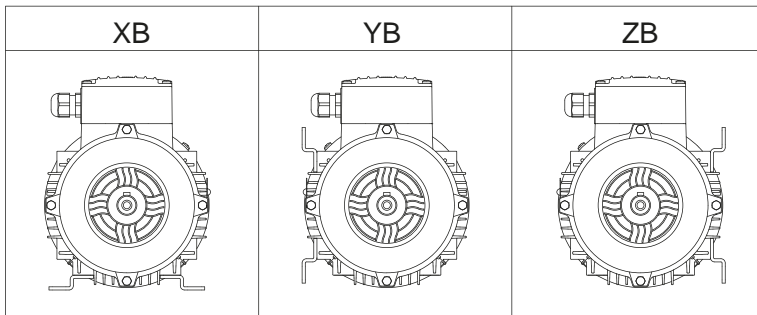

A: Cable gland on the right when viewed from the drive side
 B: Cable gland on the left when viewed from the drive side
 C: Cable gland at the rear when viewed from the drive side
 D: Cable gland at the front when viewed from the drive side

Optionally, if feet are not desired on the motor, mounting positions other than X, Y, and Z are available.

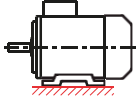
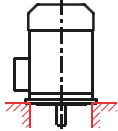
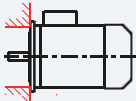
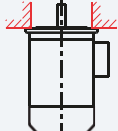
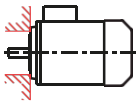
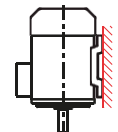
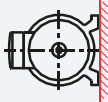
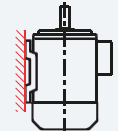
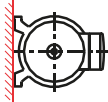
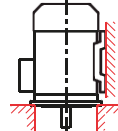

Construction Types

ELK motors are manufactured in accordance with International Mounting Standard IEC 60034-7.

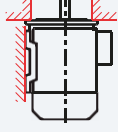
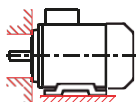
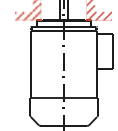
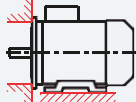
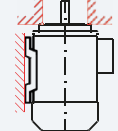
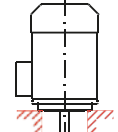
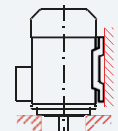
| Mounting codes and diagrams according to IEC 60034-7 | | | | | |
|---|--------|---------|---|--------|---------|
| Horizontal Mounting Codes | | | Vertical Mounting Codes | | |
| | I | II | | I | II |
|  | IM B3 | IM 1001 |  | IM V1 | IM 3011 |
|  | IM B5 | IM 3001 |  | IM V3 | IM 3031 |
|  | IM B14 | IM 3601 |  | IM V5 | IM 1011 |
|  | IM B7 | IM 1061 |  | IM V6 | IM 1031 |
|  | IM B6 | IM 1051 |  | IM V15 | IM 2011 |
|  | IM B8 | IM 1071 |  | IM V35 | IM 2031 |
|  | IM B34 | IM 2101 |  | IM V19 | IM 3631 |
|  | IM B35 | IM 2001 |  | IM V37 | IM 2131 |
| | | |  | IM V18 | IM 3611 |
| | | |  | IM V17 | IM 2111 |

Bearings

Standard ELK Motors are equipped with the ball bearings specified in the table, and optional NUP and NJ type bearings can also be used.

| Frame Size | Number of Poles | Drive End Bearing | Non-Drive End Bearing |
|------------|-----------------|-------------------|-----------------------|
| 63 | 2-4-6-8 | 6201 ZZ C3 | 6201 ZZ C3 |
| 71 | 2-4-6-8 | 6202 ZZ C3 | 6202 ZZ C3 |
| 80 | 2-4-6-8 | 6204 ZZ C3 | 6204 ZZ C3 |
| 90 | 2-4-6-8 | 6205 ZZ C3 | 6205 ZZ C3 |
| 100 | 2-4-6-8 | 6206 ZZ C3 | 6206 ZZ C3 |
| 112 | 2-4-6-8 | 6206 ZZ C3 | 6206 ZZ C3 |
| 132 | 2-4-6-8 | 6208 ZZ C3 | 6208 ZZ C3 |
| 160 | 2-4-6-8 | 6309 ZZ C3 | 6209 ZZ C3 |
| 180 | 2-4-6-8 | 6310 ZZ C3 | 6210 ZZ C3 |
| 200 | 2-4-6-8 | 6312 ZZ C3 | 6212 ZZ C3 |
| 225 | 2-4-6-8 | 6313 ZZ C3 | 6213 ZZ C3 |
| 250 | 2-4-6-8 | 6315 ZZ C3 | 6215 ZZ C3 |
| 280 | 2 | 6315 C3 | 6315 C3 |
| | 4-6-8 | 6317 C3 | 6317 C3 |
| 315 | 2 | 6316 C3 | 6316 C3 |
| | 4-6-8 | 6319 C3 | 6319 C3 |

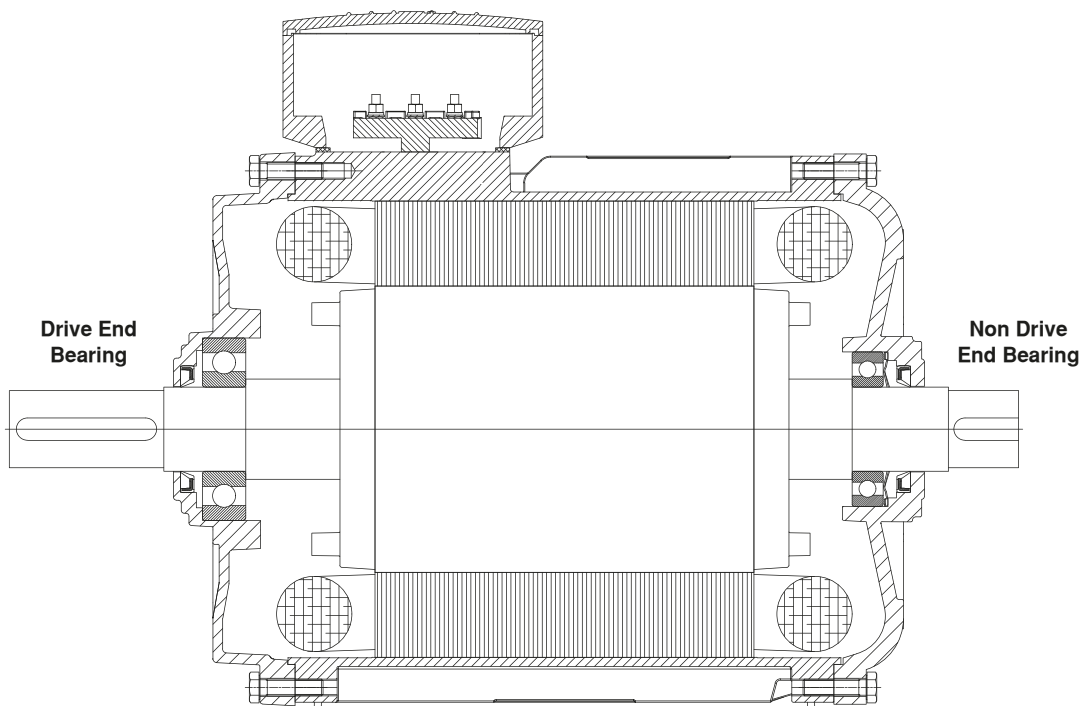

Lubrication

In open bearing applications, axial and radial loads, along with temperature and motor speed factors, affect the lubrication intervals and quantities. The lubrication intervals and quantities are theoretically calculated and specified based on the permissible maximum radial and axial Loads given in the catalog, considering temperature and speed factors. In open bearing lubrication applications, it is important to use the type and brand of grease specified by the manufacturer. ELK Motors uses MOBIL Polyrex EM for open lubrication applications. The lubrication intervals for the relevant bearings are also indicated on the motor nameplate.

50 Hz Deep Groove Ball Bearing Lubrication Intervals

| Frame | Pole | 45 °C < T ≤ 65 °C | | | | 65 °C < T ≤ 80 °C | | | | 80 °C < T ≤ 95 °C | | | |
|-------|------|-------------------|----------|------------|----------|-------------------|----------|------------|----------|-------------------|----------|------------|----------|
| | | DE | | NDE | | DE | | NDE | | DE | | NDE | |
| | | Amount [g] | Time [h] | Amount [g] | Time [h] | Amount [g] | Time [h] | Amount [g] | Time [h] | Amount [g] | Time [h] | Amount [g] | Time [h] |
| 112 | 2 | 5 | 14000 | 5 | 14000 | 5 | 6900 | 5 | 6900 | 5 | 3500 | 5 | 3500 |
| | 4 | 5 | 14000 | 5 | 20000 | 5 | 7100 | 5 | 10000 | 5 | 3600 | 5 | 5100 |
| | 6 | 5 | 16000 | 5 | 23000 | 5 | 8100 | 5 | 12000 | 5 | 4100 | 5 | 5800 |
| 132 | 2 | 7 | 11000 | 7 | 11000 | 7 | 5500 | 7 | 5500 | 7 | 2700 | 7 | 2700 |
| | 4 | 7 | 13000 | 7 | 18000 | 7 | 6300 | 7 | 9000 | 7 | 3200 | 7 | 4500 |
| | 6 | 7 | 15000 | 7 | 21000 | 7 | 7500 | 7 | 11000 | 7 | 3700 | 7 | 5400 |
| 160 | 2 | 13 | 8800 | 8 | 10000 | 13 | 4400 | 8 | 5000 | 13 | 2200 | 13 | 2500 |
| | 4 | 13 | 11000 | 8 | 17000 | 13 | 5700 | 8 | 8700 | 13 | 2800 | 13 | 4300 |
| | 6 | 13 | 14000 | 8 | 21000 | 13 | 7000 | 8 | 10000 | 13 | 3500 | 13 | 5200 |
| 180 | 2 | 15 | 7800 | 9 | 9200 | 15 | 3900 | 9 | 4600 | 15 | 1900 | 15 | 2300 |
| | 4 | 15 | 11000 | 9 | 17000 | 15 | 5300 | 9 | 8300 | 15 | 2700 | 15 | 4200 |
| | 6 | 15 | 13000 | 9 | 20000 | 15 | 6700 | 9 | 10000 | 15 | 3300 | 15 | 5100 |
| 200 | 2 | 20 | 6000 | 12 | 7200 | 20 | 3000 | 12 | 3600 | 20 | 1500 | 12 | 1800 |
| | 4 | 20 | 9400 | 12 | 15000 | 20 | 4700 | 12 | 7300 | 20 | 2400 | 12 | 3700 |
| | 6 | 20 | 12000 | 12 | 19000 | 20 | 6200 | 12 | 9300 | 20 | 3100 | 12 | 4700 |
| 225 | 2 | 23 | 5300 | 14 | 6300 | 23 | 2700 | 14 | 3200 | 23 | 1300 | 14 | 1600 |
| | 4 | 23 | 8900 | 14 | 14000 | 23 | 4400 | 14 | 6900 | 23 | 2200 | 14 | 3400 |
| | 6 | 23 | 12000 | 14 | 18000 | 23 | 5900 | 14 | 8900 | 23 | 3000 | 14 | 4500 |
| 250 | 2 | 30 | 4100 | 16 | 5300 | 30 | 2100 | 16 | 2700 | 30 | 1000 | 16 | 1300 |
| | 4 | 30 | 7800 | 16 | 13000 | 30 | 3900 | 16 | 6300 | 30 | 1900 | 16 | 3200 |
| | 6 | 30 | 11000 | 16 | 17000 | 30 | 5400 | 16 | 8400 | 30 | 2700 | 16 | 4200 |
| 280 | 2 | 30 | 4100 | 30 | 4100 | 30 | 2100 | 30 | 2100 | 30 | 1000 | 30 | 1000 |
| | 4 | 37 | 6900 | 37 | 9800 | 37 | 3400 | 37 | 4900 | 37 | 1700 | 37 | 2500 |
| | 6 | 37 | 10000 | 37 | 14000 | 37 | 5000 | 37 | 7100 | 37 | 2500 | 37 | 3600 |
| 315 | 2 | 33 | 3600 | 33 | 3600 | 33 | 1800 | 33 | 1800 | 33 | 910 | 33 | 910 |
| | 4 | 45 | 6100 | 45 | 8700 | 45 | 3000 | 45 | 4300 | 45 | 1500 | 45 | 2200 |
| | 6 | 45 | 9200 | 45 | 13000 | 45 | 4600 | 45 | 6500 | 45 | 2300 | 45 | 3300 |

* The "T" value specified in the table is the bearing temperature.

60 Hz Deep Groove Ball Bearing Lubrication Intervals

| Frame | Pole | 45 °C < T ≤ 65 °C | | | | 65 °C < T ≤ 80 °C | | | | 80 °C < T ≤ 95 °C | | | |
|-------|------|-------------------|----------|------------|----------|-------------------|----------|------------|----------|-------------------|----------|------------|----------|
| | | DE | | NDE | | DE | | NDE | | DE | | NDE | |
| | | Amount [g] | Time [h] | Amount [g] | Time [h] | Amount [g] | Time [h] | Amount [g] | Time [h] | Amount [g] | Time [h] | Amount [g] | Time [h] |
| 112 | 2 | 5 | 12000 | 5 | 12000 | 5 | 5900 | 5 | 5900 | 5 | 3000 | 5 | 3000 |
| | 4 | 5 | 13000 | 5 | 19000 | 5 | 6600 | 5 | 9400 | 5 | 3300 | 5 | 4700 |
| | 6 | 5 | 15000 | 5 | 22000 | 5 | 7700 | 5 | 11000 | 5 | 3800 | 5 | 5500 |
| 132 | 2 | 7 | 8900 | 7 | 8900 | 7 | 4500 | 7 | 4500 | 7 | 2200 | 7 | 2200 |
| | 4 | 7 | 11000 | 7 | 16000 | 7 | 5700 | 7 | 8200 | 7 | 2900 | 7 | 4100 |
| | 6 | 7 | 14000 | 7 | 20000 | 7 | 7000 | 7 | 10000 | 7 | 3500 | 7 | 5000 |
| 160 | 2 | 13 | 6900 | 8 | 8100 | 13 | 3500 | 8 | 4000 | 13 | 1700 | 8 | 2000 |
| | 4 | 13 | 10000 | 8 | 16000 | 13 | 5000 | 8 | 7800 | 13 | 2500 | 8 | 3900 |
| | 6 | 13 | 13000 | 8 | 19000 | 13 | 6400 | 8 | 9700 | 13 | 3200 | 8 | 4800 |
| 180 | 2 | 15 | 5900 | 9 | 7300 | 15 | 3000 | 9 | 3600 | 15 | 1500 | 9 | 1800 |
| | 4 | 15 | 9300 | 9 | 15000 | 15 | 4700 | 9 | 7400 | 15 | 2300 | 9 | 3700 |
| | 6 | 15 | 12000 | 9 | 19000 | 15 | 6100 | 9 | 9400 | 15 | 3100 | 9 | 4700 |
| 200 | 2 | 20 | 4400 | 12 | 5400 | 20 | 2200 | 12 | 2700 | 20 | 1100 | 12 | 1300 |
| | 4 | 20 | 8000 | 12 | 13000 | 20 | 4000 | 12 | 6300 | 20 | 2000 | 12 | 3200 |
| | 6 | 20 | 11000 | 12 | 17000 | 20 | 5500 | 12 | 8500 | 20 | 2800 | 12 | 4200 |
| 225 | 2 | 23 | 3800 | 14 | 4600 | 23 | 1900 | 14 | 2300 | 23 | 940 | 14 | 1200 |
| | 4 | 23 | 7400 | 14 | 12000 | 23 | 3700 | 14 | 5900 | 23 | 1900 | 14 | 2900 |
| | 6 | 23 | 11000 | 14 | 16000 | 23 | 5300 | 14 | 8000 | 23 | 2600 | 14 | 4000 |
| 250 | 2 | 30 | 2800 | 16 | 3800 | 30 | 1400 | 16 | 1900 | 30 | 700 | 16 | 940 |
| | 4 | 30 | 6400 | 16 | 11000 | 30 | 3200 | 16 | 5300 | 30 | 1600 | 16 | 2700 |
| | 6 | 30 | 9500 | 16 | 15000 | 30 | 4800 | 16 | 7500 | 30 | 2400 | 16 | 3800 |
| 280 | 2 | 30 | 2800 | 30 | 2800 | 30 | 1400 | 30 | 1400 | 30 | 700 | 30 | 700 |
| | 4 | 37 | 5500 | 37 | 7900 | 37 | 2700 | 37 | 3900 | 37 | 1400 | 37 | 2000 |
| | 6 | 37 | 8600 | 37 | 12000 | 37 | 4300 | 37 | 6100 | 37 | 2100 | 37 | 3100 |
| 315 | 2 | 33 | 2400 | 33 | 2400 | 33 | 1200 | 33 | 1200 | 33 | 600 | 33 | 600 |
| | 4 | 45 | 4700 | 45 | 6700 | 45 | 2400 | 45 | 3400 | 45 | 1200 | 45 | 1700 |
| | 6 | 45 | 7800 | 45 | 11000 | 45 | 3900 | 45 | 5500 | 45 | 1900 | 45 | 2800 |

* The "T" value specified in the table is the bearing temperature.

50 Hz Cylindrical Roller Bearing Lubrication Intervals

| Frame | Pole | 45 °C < T ≤ 65 °C | | 65 °C < T ≤ 80 °C | | 80 °C < T ≤ 95 °C | |
|-------|------|-------------------|----------|-------------------|----------|-------------------|----------|
| | | DE | | DE | | DE | |
| | | Amount [g] | Time [h] | Amount [g] | Time [h] | Amount [g] | Time [h] |
| 132 | 2 | 10 | 2000 | 10 | 1000 | 10 | 510 |
| | 4 | 10 | 4600 | 10 | 2300 | 10 | 1200 |
| | 6 | 10 | 6100 | 10 | 3000 | 10 | 1500 |
| 160 | 2 | 13 | 1700 | 13 | 840 | 13 | 420 |
| | 4 | 13 | 4200 | 13 | 2100 | 13 | 1000 |
| | 6 | 13 | 5700 | 13 | 2800 | 13 | 1400 |
| 180 | 2 | 15 | 1400 | 15 | 700 | 15 | 350 |
| | 4 | 15 | 3800 | 15 | 1900 | 15 | 1000 |
| | 6 | 15 | 5300 | 15 | 2700 | 15 | 1300 |
| 200 | 2 | 20 | 950 | 20 | 480 | 20 | 240 |
| | 4 | 20 | 3200 | 20 | 1600 | 20 | 800 |
| | 6 | 20 | 4700 | 20 | 2400 | 20 | 1200 |
| 225 | 2 | 23 | 800 | 23 | 400 | 23 | 200 |
| | 4 | 23 | 3000 | 23 | 1500 | 23 | 750 |
| | 6 | 23 | 4400 | 23 | 2200 | 23 | 1100 |
| 250 | 2 | 30 | 540 | 30 | 270 | 30 | 130 |
| | 4 | 30 | 2400 | 30 | 1200 | 30 | 600 |
| | 6 | 30 | 4000 | 30 | 2000 | 30 | 1000 |
| 280 | 2 | 30 | 540 | 30 | 270 | 30 | 130 |
| | 4 | 30 | 2400 | 30 | 1200 | 30 | 600 |
| | 6 | 30 | 3900 | 30 | 1900 | 30 | 970 |
| 315 | 2 | 33 | 440 | 33 | 220 | 33 | 110 |
| | 4 | 33 | 2200 | 33 | 1100 | 33 | 540 |
| | 6 | 33 | 3700 | 33 | 1800 | 33 | 920 |

* The "T" value specified in the table is the bearing temperature.

Bearing Lubrication Schematic

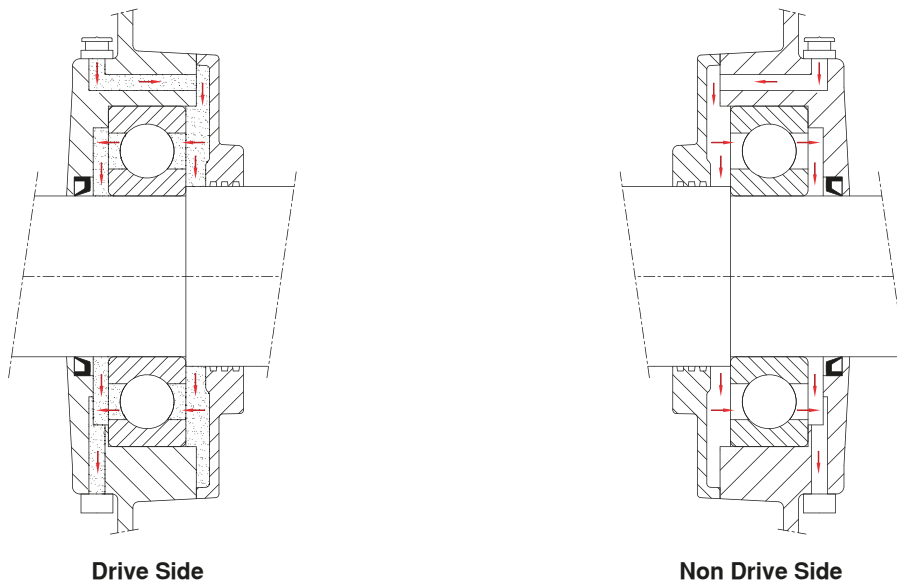

Radial Loads

Radial Load on the Shaft (FR):

The radial load can be calculated using the following formula.

The calculated radial load should not exceed the permissible values specified in the tables ($FR < Fr_x$).

If it does, please consult us.

$$F_R = k \cdot \frac{P}{D \cdot n} \cdot 10^7 \text{ (N)}$$

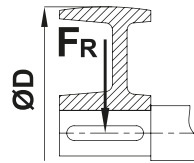

Correction of Permissible Radial Load (Fr_x):

If the radial load acting on the shaft is between the x_0 and x_{max} values, the permissible value should be corrected using the following formula.

$$Fr_x = Fr_0 - \frac{x}{E} (Fr_0 - Fr_{max})$$

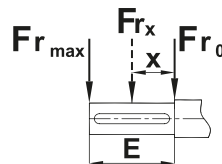

P: Motor Power (kW)
 D: Shaft Diameter (mm)
 n: Motor Speed (rpm)
 k: Radial Load Factor

- Spur Gears, chain drives with low speed = 2.1
- Trigger Belts = 2,5
- V type belts = 5

$FR < Fr_x$: The radial load on the shaft must be less than the permissible maximum radial load.

Fa: Axial load acting on the shaft.

Fr0: Permissible maximum radial load on the shaft.

Fr max: Permissible maximum radial load at the end of the shaft.

Permissible load calculations are based on a bearing life of Lh10 20,000 hours according to ISO 281.

Radial Loads

HORIZONTAL MOUNTING - Permissible Radial Loads
 Mounting Positions IM: B3, B5, B6, B7, B8, B14, B34, B35

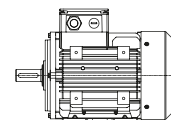

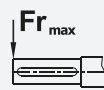
| Frame Size | Fa = 0 | |
|-----------------------------|---|---|
| |  |  |
| 2 Poles 3000 rpm | Fr₀ [N] | Fr_{max} [N] |
| 63 | 350 | 300 |
| 71 | 380 | 340 |
| 80 | 640 | 550 |
| 90 | 750 | 660 |
| 100 | 1050 | 900 |
| 112 | 1050 | 910 |
| 132 | 1520 | 1220 |
| 160 | 2800 | 2300 |
| 180 | 3250 | 2650 |
| 200 | 4340 | 3560 |
| 225 | 4950 | 4000 |
| 250 | 6050 | 4800 |
| 280 | 6300 | 5100 |
| 315 | 6400 | 5550 |
| 4 Poles 1500 rpm | Fr₀ [N] | Fr_{max} [N] |
| 63 | 430 | 390 |
| 71 | 520 | 440 |
| 80 | 800 | 700 |
| 90 | 950 | 780 |
| 100 | 1300 | 1050 |
| 112 | 1300 | 1050 |
| 132 | 1950 | 1600 |
| 160 | 3540 | 2825 |
| 180 | 4100 | 3400 |
| 200 | 5500 | 4550 |
| 225 | 6200 | 4900 |
| 250 | 7500 | 6000 |
| 280 | 8200 | 7500 |
| 315 | 8500 | 8000 |
| 6 Poles 1000 rpm | Fr₀ [N] | Fr_{max} [N] |
| 71 | 580 | 500 |
| 80 | 870 | 800 |
| 90 | 1090 | 900 |
| 100 | 1500 | 1250 |
| 112 | 1500 | 1250 |
| 132 | 2200 | 1800 |
| 160 | 4050 | 3190 |
| 180 | 4720 | 3830 |
| 200 | 6350 | 5150 |
| 225 | 7350 | 5650 |
| 250 | 8950 | 7200 |
| 280 | 9500 | 8500 |
| 315 | 9800 | 8700 |

Fa0 : Permissible maximum axial load

Fr : Radial force acting on the shaft

Fr0 : Permissible maximum radial load at the end of the shaft

Fr max : Permissible maximum radial load at the shaft end

Permissible load calculations are based on a bearing life of Lh10 20,000 hours according to ISO 281.

Axial Loads

HORIZONTAL MOUNTING - Permissible Axial Loads
 Mounting Positions IM: B3, B5, B6, B7, B8, B14, B34, B35

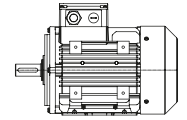

| Frame Size | Push | | | Pull |
|-----------------------------|----------------|----------------------|------------------------|----------------|
| | Fr = 0 | Fr = Fr ₀ | Fr = Fr _{max} | Fr = 0 |
| | | | | |
| 2 Poles 3000 rpm | Fa0 [N] | Fa0 [N] | Fa0 [N] | Fa0 [N] |
| 63 | 90 | 90 | 90 | 220 |
| 71 | 110 | 110 | 110 | 250 |
| 80 | 190 | 190 | 190 | 395 |
| 90 | 210 | 210 | 210 | 400 |
| 100 | 270 | 270 | 270 | 580 |
| 112 | 270 | 270 | 270 | 580 |
| 132 | 380 | 380 | 370 | 800 |
| 160 | 2280 | 1060 | 1020 | 1670 |
| 180 | 2660 | 1250 | 1250 | 1970 |
| 200 | 3150 | 1500 | 1390 | 2600 |
| 225 | 3850 | 1850 | 1760 | 2750 |
| 250 | 4150 | 2180 | 2250 | 3350 |
| 280 | 4500 | 2500 | 2500 | 3350 |
| 315 | 5200 | 2700 | 2700 | 3410 |
| 4 Poles 1500 rpm | Fa0 [N] | Fa0 [N] | Fa0 [N] | Fa0 [N] |
| 63 | 90 | 90 | 90 | 330 |
| 71 | 110 | 110 | 110 | 360 |
| 80 | 190 | 190 | 190 | 560 |
| 90 | 210 | 210 | 210 | 585 |
| 100 | 300 | 300 | 300 | 830 |
| 112 | 300 | 300 | 300 | 830 |
| 132 | 400 | 400 | 400 | 1200 |
| 160 | 2280 | 1400 | 1400 | 2350 |
| 180 | 3100 | 1570 | 1500 | 2800 |
| 200 | 4400 | 1770 | 1770 | 3810 |
| 225 | 4950 | 2150 | 2200 | 4300 |
| 250 | 6050 | 2400 | 2400 | 4500 |
| 280 | 7200 | 3000 | 3000 | 5500 |
| 315 | 7800 | 4000 | 3700 | 5800 |
| 6 Poles 1000 rpm | Fa0 [N] | Fa0 [N] | Fa0 [N] | Fa0 [N] |
| 71 | 110 | 110 | 110 | 430 |
| 80 | 190 | 190 | 190 | 700 |
| 90 | 210 | 210 | 210 | 740 |
| 100 | 290 | 290 | 290 | 1020 |
| 112 | 290 | 290 | 290 | 1020 |
| 132 | 380 | 380 | 380 | 1470 |
| 160 | 3050 | 1540 | 1520 | 2900 |
| 180 | 3540 | 1780 | 1700 | 3410 |
| 200 | 4800 | 2200 | 2250 | 4400 |
| 225 | 5050 | 2580 | 2800 | 5200 |
| 250 | 6050 | 3100 | 3150 | 6500 |
| 280 | 7000 | 3700 | 3400 | 7150 |
| 315 | 8500 | 4200 | 3800 | 6900 |

Fa0 : Permissible maximum axial load

Fr : Radial force acting on the shaft

Fr0 : Permissible maximum radial load at the end of the shaft

Fr max : Permissible maximum radial load at the shaft end

Permissible load calculations are based on a bearing life of Lh10 20,000 hours according to ISO 281.

Axial Loads

VERTICAL MOUNTING - Shaft Pointing Upwards - Permissible Axial Loads
 Mounting Positions IM: V3, V6, V19, V35, V37

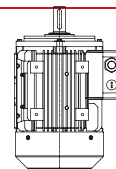

| Frame Size | Push | | | Pull |
|-----------------------------|-------------------------------|-------------------------------|-------------------------------|-------------------------------|
| | Fr = 0 | Fr = Fr ₀ | Fr = Fr _{max} | Fr = 0 |
| | | | | |
| 2 Poles 3000 rpm | Fa₀ [N] | Fa₀ [N] | Fa₀ [N] | Fa₀ [N] |
| 63 | 90 | 90 | 90 | 230 |
| 71 | 100 | 100 | 100 | 265 |
| 80 | 170 | 170 | 170 | 425 |
| 90 | 180 | 180 | 180 | 450 |
| 100 | 250 | 250 | 250 | 650 |
| 112 | 250 | 250 | 250 | 660 |
| 132 | 300 | 300 | 300 | 970 |
| 160 | 2080 | 1060 | 990 | 1950 |
| 180 | 2410 | 1190 | 1050 | 2350 |
| 200 | 2900 | 1265 | 1265 | 3000 |
| 225 | 3250 | 1310 | 1295 | 3575 |
| 250 | 3950 | 1460 | 1450 | 4350 |
| 280 | 4100 | 1500 | 1500 | 4700 |
| 315 | 4380 | 1420 | 1420 | 5250 |
| 4 Poles 1500 rpm | Fa₀ [N] | Fa₀ [N] | Fa₀ [N] | Fa₀ [N] |
| 63 | 90 | 90 | 90 | 345 |
| 71 | 95 | 95 | 95 | 380 |
| 80 | 160 | 160 | 160 | 600 |
| 90 | 170 | 170 | 170 | 650 |
| 100 | 210 | 210 | 210 | 930 |
| 112 | 210 | 210 | 210 | 950 |
| 132 | 240 | 240 | 240 | 1430 |
| 160 | 2500 | 1250 | 1220 | 2160 |
| 180 | 2900 | 1400 | 1370 | 2570 |
| 200 | 3900 | 1360 | 1530 | 3500 |
| 225 | 4450 | 1570 | 1680 | 4000 |
| 250 | 5400 | 1870 | 1910 | 4300 |
| 280 | 6500 | 2250 | 2250 | 7100 |
| 315 | 6000 | 2050 | 1600 | 8850 |
| 6 Poles 1000 rpm | Fa₀ [N] | Fa₀ [N] | Fa₀ [N] | Fa₀ [N] |
| 71 | 95 | 95 | 95 | 455 |
| 80 | 160 | 160 | 160 | 745 |
| 90 | 170 | 170 | 170 | 800 |
| 100 | 230 | 230 | 230 | 1120 |
| 112 | 210 | 210 | 210 | 1150 |
| 132 | 250 | 250 | 250 | 1690 |
| 160 | 2980 | 1490 | 1450 | 3300 |
| 180 | 3400 | 1670 | 1670 | 3800 |
| 200 | 4250 | 1850 | 1860 | 5100 |
| 225 | 4800 | 1980 | 2080 | 5800 |
| 250 | 5300 | 2200 | 2260 | 6200 |
| 280 | 6300 | 2200 | 2050 | 7500 |
| 315 | 6800 | 2290 | 2200 | 10750 |

Fa₀ : Permissible maximum axial load

Fr : Radial force acting on the shaft

Fr₀ : Permissible maximum radial load at the end of the shaft

Fr_{max} : Permissible maximum radial load at the shaft end

Permissible load calculations are based on a bearing life of L_{h10} 20,000 hours according to ISO 281.

Axial Loads

VERTICAL MOUNTING – Shaft Pointing Downwards - Permissible Axial Loads
 Mounting Positions IM: V1, V5, V15, V17, V18

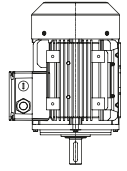

| Frame Size | Push | | | Pull |
|-----------------------------|-------------------------------|-------------------------------|-------------------------------|-------------------------------|
| | Fr = 0 | Fr = Fr ₀ | Fr = Fr _{max} | Fr = 0 |
| | | | | |
| 2 Poles 3000 rpm | Fa₀ [N] | Fa₀ [N] | Fa₀ [N] | Fa₀ [N] |
| 63 | 110 | 110 | 110 | 210 |
| 71 | 130 | 130 | 130 | 235 |
| 80 | 220 | 220 | 220 | 385 |
| 90 | 250 | 250 | 250 | 375 |
| 100 | 330 | 330 | 330 | 535 |
| 112 | 340 | 340 | 340 | 520 |
| 132 | 490 | 550 | 550 | 680 |
| 160 | 2600 | 1550 | 1500 | 1500 |
| 180 | 3070 | 1850 | 1750 | 1700 |
| 200 | 3550 | 2300 | 2300 | 2315 |
| 225 | 4250 | 2680 | 2670 | 2630 |
| 250 | 5200 | 3200 | 3280 | 3100 |
| 280 | 6000 | 3900 | 3900 | 2750 |
| 315 | 7320 | 4370 | 4350 | 2825 |
| 4 Poles 1500 rpm | Fa₀ [N] | Fa₀ [N] | Fa₀ [N] | Fa₀ [N] |
| 63 | 120 | 110 | 120 | 300 |
| 71 | 130 | 130 | 130 | 340 |
| 80 | 220 | 220 | 220 | 540 |
| 90 | 260 | 260 | 260 | 545 |
| 100 | 380 | 370 | 370 | 760 |
| 112 | 410 | 400 | 400 | 740 |
| 132 | 580 | 570 | 570 | 1040 |
| 160 | 3500 | 1910 | 1840 | 2100 |
| 180 | 4000 | 2300 | 2170 | 2450 |
| 200 | 4250 | 2870 | 2850 | 2200 |
| 225 | 5000 | 3350 | 3380 | 3740 |
| 250 | 6200 | 4200 | 4000 | 4440 |
| 280 | 8900 | 4850 | 4850 | 4600 |
| 315 | 10900 | 6950 | 6500 | 3900 |
| 6 Poles 1000 rpm | Fa₀ [N] | Fa₀ [N] | Fa₀ [N] | Fa₀ [N] |
| 71 | 130 | 130 | 130 | 415 |
| 80 | 220 | 220 | 220 | 675 |
| 90 | 250 | 250 | 250 | 700 |
| 100 | 360 | 360 | 360 | 960 |
| 112 | 390 | 390 | 390 | 930 |
| 132 | 560 | 560 | 560 | 1310 |
| 160 | 3100 | 2130 | 2120 | 2650 |
| 180 | 3600 | 2600 | 2490 | 3030 |
| 200 | 5000 | 3260 | 3300 | 4000 |
| 225 | 5550 | 3710 | 3810 | 4650 |
| 250 | 6200 | 4510 | 4550 | 5500 |
| 280 | 7500 | 5300 | 5200 | 5750 |
| 315 | 12800 | 7400 | 7800 | 5500 |

Fa₀ : Permissible maximum axial load

Fr : Radial force acting on the shaft

Fr₀ : Permissible maximum radial load at the end of the shaft

Fr_{max} : Permissible maximum radial load at the shaft end

Permissible load calculations are based on a bearing life of L_{h10} 20,000 hours according to ISO 281.

Radial Loads (NUP)

HORIZONTAL MOUNTING - Permissible Radial Loads
 Mounting Positions IM: B3, B5, B6, B7, B8, B14, B34, B35

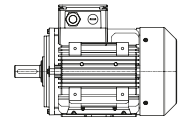

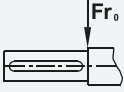
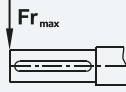
| Frame Size | Fa = 0 | |
|-----------------------------|---|---|
| |  |  |
| 2 Poles 3000 rpm | Fr₀ [N] | Fr_{max} [N] |
| 132 | 6800 | 5200 |
| 160 | 8200 | 4500 |
| 180 | 9500 | 7300 |
| 200 | 12700 | 10400 |
| 225 | 15500 | 11300 |
| 250 | 20500 | 13600 |
| 280 | 20500 | 17000 |
| 315 | 22000 | 18500 |
| 4 Poles 1500 rpm | Fr₀ [N] | Fr_{max} [N] |
| 132 | 8500 | 6500 |
| 160 | 10000 | 6300 |
| 180 | 11500 | 9300 |
| 200 | 15500 | 12800 |
| 225 | 19000 | 14500 |
| 250 | 25000 | 17500 |
| 280 | 31000 | 26000 |
| 315 | 35000 | 30000 |
| 6 Poles 1000 rpm | Fr₀ [N] | Fr_{max} [N] |
| 132 | 9500 | 7600 |
| 160 | 11500 | 7100 |
| 180 | 13000 | 10500 |
| 200 | 17500 | 14500 |
| 225 | 21500 | 16500 |
| 250 | 28500 | 19500 |
| 280 | 35000 | 29000 |
| 315 | 40000 | 34000 |

Fa0 : Permissible maximum axial load

Fr : Radial force acting on the shaft

Fr0 : Permissible maximum radial load at the end of the shaft

Fr max : Permissible maximum radial load at the shaft end

Permissible load calculations are based on a bearing life of Lh10 20,000 hours according to ISO 281.

Product Type Codes of Three-Phase Motors

4 EL 160 L 4 F PD BA 000

| | | |
|-----|--------|---|
| 4 | -----> | Motor Efficiency Classes: 2: IE2 3: IE3 4: IE4 |
| EL | -----> | Basic Motor Type EL : Aluminum housing standard three-phase motors EG : Cast iron housing standard three-phase motors EC : Aluminum housing three-phase compact motors ED : Cast iron housing three-phase compact motors |
| 160 | -----> | Frame Size: 63, 71, 80, 90, 100, 112, 132, 160, 180, 200, 225, 250, 280, 315 Height of the shaft axis from feet base of motor (mm) |
| L | -----> | Housing Length S : Short M: Medium L : Long |
| 4 | -----> | Number of Poles 2: 2 Poles 3000 rpm 4: 4 Poles 1500 rpm 6: 6 Poles 1000 rpm 8: 8 Poles 750 rpm |
| F | -----> | Core Length: A, B, C, D, E, F, G |
| PD | -----> | Construction Types Flange Types PD : B3 Foot Mounted FA : B5 Flange FB : B14/2 Flange PB : B14/2 Feet FC : B14 Flange FS : Special Flange PA : B35 PC : B34 PS : Foot mounted with special flange Y0..Y9 : With flange for gearbox connection PX : Foot mounted without drive end shield XX : Without foot and drive end shield Z0-Z9 : Foot mounted Yılmaz type |
| BA | -----> | Electrical Specifications AA..ZZ Voltage, Frequency and electrical features 1st digit : Voltage and Frequency A : 230/400V 50Hz B : 400/690V 50Hz C : 240/415V 50Hz D : 415/720V 50Hz E : 230/400V 60Hz F : 400/690V 60Hz G : 220V 60Hz H : 290/500V 50Hz I : 220/380V 60Hz J : 380/660V 60Hz 2nd digit : Additional electrical features 0: Standard motor, basic version A: Motors with thermistor B: Motors with anti-condensation heater C: Motors with thermal switch D: Motors with PT100 Temperature sensor J: Motors with PT1000 Temperature sensor K: Motors with thermistor and anti-condensation heater |
| 000 | -----> | Additional Motor Features 000 : Standard Motor |

THREE-PHASE MOTORS



Motors



Electrical Characteristics

400V 50Hz 3000 d/d

Duty Cycle : S1 (Continuous Operation)
 Insulation Class : F (155°C)
 Temperature Raise : B (80°K)



| Voltage (V) | Type | Rated Values | | | | | | | Starting Values | | Break Down Torque | Moment of Inertia | B3 Motor Weight | Sound Pressure Level | |
|-------------|-----------|--------------|-------|---------|--------|--------------|---------------------|------|-----------------|--------------------------------|-------------------|-------------------|-----------------|----------------------|--------------------------------|
| | | Power | Speed | Current | Torque | Power Factor | Efficiency % η | | | Current | | | | | Torque |
| | | kW | rpm | A | Nm | Cos ϕ | 4/4 | 3/4 | 1/2 | I _A /I _N | | | | | M _A /M _N |
| 230/400 | 2EL063M2A | 0,18 | 2800 | 0,50 | 0,61 | 0,77 | 67,5 | 66,0 | 62,0 | 4,5 | 2,9 | 3,0 | 0,00012 | 3,80 | 51 |
| | 2EL063M2B | 0,25 | 2800 | 0,67 | 0,85 | 0,78 | 69,0 | 68,0 | 63,5 | 4,5 | 2,9 | 3,0 | 0,00015 | 4,00 | 51 |
| | 2EL071M2A | 0,37 | 2790 | 0,90 | 1,26 | 0,80 | 74,2 | 74,5 | 72,5 | 5,0 | 2,5 | 2,8 | 0,00031 | 5,70 | 54 |
| | 2EL071M2B | 0,55 | 2790 | 1,27 | 1,88 | 0,82 | 75,8 | 77,0 | 76,0 | 5,0 | 2,8 | 2,9 | 0,00037 | 6,20 | 54 |

Our UL approved motors have the logo on their nameplates.

400V 50Hz 1500 d/d

Duty Cycle : S1 (Continuous Operation)
 Insulation Class : F (155°C)
 Temperature Raise : B (80°K)



| Voltage (V) | Type | Rated Values | | | | | | | Starting Values | | Break Down Torque | Moment of Inertia | B3 Motor Weight | Sound Pressure Level | |
|-------------|-----------|--------------|-------|---------|--------|--------------|---------------------|------|-----------------|--------------------------------|-------------------|-------------------|-----------------|----------------------|--------------------------------|
| | | Power | Speed | Current | Torque | Power Factor | Efficiency % η | | | Current | | | | | Torque |
| | | kW | rpm | A | Nm | Cos ϕ | 4/4 | 3/4 | 1/2 | I _A /I _N | | | | | M _A /M _N |
| 230/400 | 2EL063M4B | 0,12 | 1400 | 0,42 | 0,82 | 0,70 | 60,1 | 60,5 | 54,5 | 3,0 | 2,1 | 2,3 | 0,00018 | 4,00 | 42 |
| | 2EL063M4C | 0,18 | 1400 | 0,56 | 1,23 | 0,71 | 64,7 | 65,8 | 61,5 | 3,0 | 2,1 | 2,3 | 0,00022 | 4,40 | 42 |
| | 2EL071M4B | 0,25 | 1425 | 0,71 | 1,68 | 0,69 | 74,0 | 73,5 | 70,5 | 4,4 | 2,0 | 3,0 | 0,00067 | 6,30 | 46 |
| | 2EL071M4C | 0,37 | 1425 | 1,00 | 2,47 | 0,70 | 76,1 | 75,5 | 71,5 | 4,6 | 2,0 | 3,0 | 0,00082 | 7,00 | 46 |
| | 2EL080M4B | 0,55 | 1440 | 1,45 | 3,65 | 0,71 | 77,1 | 76,7 | 75,0 | 5,2 | 2,0 | 3,0 | 0,00175 | 9,70 | 50 |

400V 50Hz 1000 d/d

Duty Cycle : S1 (Continuous Operation)
 Insulation Class : F (155°C)
 Temperature Raise : B (80°K)



| Voltage (V) | Type | Rated Values | | | | | | | Starting Values | | Break Down Torque | Moment of Inertia | B3 Motor Weight | Sound Pressure Level | |
|-------------|----------|--------------|-------|---------|--------|--------------|---------------------|------|-----------------|--------------------------------|-------------------|-------------------|-----------------|----------------------|--------------------------------|
| | | Power | Speed | Current | Torque | Power Factor | Efficiency % η | | | Current | | | | | Torque |
| | | kW | rpm | A | Nm | Cos ϕ | 4/4 | 3/4 | 1/2 | I _A /I _N | | | | | M _A /M _N |
| 230/400 | 2EL71M6B | 0,18 | 920 | 0,60 | 1,87 | 0,67 | 64,5 | 63,0 | 57,0 | 3,2 | 1,9 | 2,3 | 0,00076 | 6,10 | 42 |
| | 2EL71M6C | 0,25 | 920 | 0,78 | 2,59 | 0,69 | 66,5 | 66,0 | 61,0 | 3,3 | 1,9 | 2,3 | 0,00096 | 6,70 | 42 |
| | 2EL80M6A | 0,37 | 925 | 1,08 | 3,82 | 0,69 | 71,4 | 71,5 | 70,0 | 4,0 | 2,0 | 2,6 | 0,00176 | 9,10 | 45 |
| | 2EL80M6B | 0,55 | 932 | 1,50 | 5,64 | 0,72 | 73,5 | 74,0 | 71,0 | 4,2 | 2,1 | 2,6 | 0,00202 | 9,80 | 45 |

Our UL approved motors have the logo on their nameplates.



THREE-PHASE MOTORS



EFFIE3 Motors



Electrical Characteristics

400V 50Hz 3000 d/d

Duty Cycle : S1 (Continuous Operation)
 Insulation Class : F (155°C)
 Temperature Raise : B (80°K)



| Voltage (V) | Type | Rated Values | | | | | | | | | Starting Values | | Break Down Torque | Moment of Inertia | B3 Motor Weight | Sound Pressure Level |
|-------------|-----------|--------------|-------|---------|--------|--------------|---------------------|------|------|--------------------------------|--------------------------------|-----|-------------------|-------------------|-----------------|----------------------|
| | | Power | Speed | Current | Torque | Power Factor | Efficiency % η | | | Current | Torque | | | | | |
| | | kW | rpm | A | Nm | Cos ϕ | 4/4 | 3/4 | 1/2 | I _A /I _N | M _A /M _N | | | | | |
| 230/400 | 3EL063M2A | 0,18 | 2805 | 0,48 | 0,61 | 0,77 | 70,0 | 68,5 | 62,8 | 4,5 | 3,0 | 3,1 | 0,00012 | 4,00 | 51 | |
| | 3EL063M2B | 0,25 | 2805 | 0,65 | 0,85 | 0,79 | 71,0 | 69,7 | 64,2 | 4,6 | 3,0 | 3,1 | 0,00015 | 4,20 | 51 | |
| | 3EL071M2B | 0,37 | 2830 | 0,84 | 1,25 | 0,82 | 76,6 | 77,0 | 75,0 | 6,0 | 2,8 | 3,0 | 0,00037 | 6,30 | 53 | |
| | 3EL071M2C | 0,55 | 2830 | 1,19 | 1,86 | 0,84 | 79,4 | 80,2 | 78,8 | 6,1 | 2,9 | 3,3 | 0,00046 | 7,00 | 53 | |
| | 3EL080M2B | 0,75 | 2880 | 1,59 | 2,49 | 0,84 | 80,7 | 82,0 | 81,5 | 6,7 | 3,0 | 3,6 | 0,00103 | 9,60 | 54 | |
| | 3EL080M2C | 1,10 | 2880 | 2,26 | 3,64 | 0,85 | 82,7 | 83,0 | 82,4 | 6,8 | 3,1 | 3,8 | 0,00124 | 10,9 | 54 | |
| | 3EL090S2B | 1,50 | 2900 | 2,97 | 4,94 | 0,86 | 84,8 | 85,4 | 84,2 | 7,6 | 3,1 | 3,9 | 0,00178 | 15,2 | 59 | |
| | 3EL090L2C | 2,20 | 2900 | 4,25 | 7,24 | 0,87 | 85,9 | 86,8 | 86,1 | 7,2 | 3,0 | 3,8 | 0,00221 | 17,5 | 59 | |
| | 3EL100L2C | 3,00 | 2910 | 5,58 | 9,85 | 0,89 | 87,1 | 87,6 | 86,9 | 7,9 | 3,0 | 4,1 | 0,00450 | 23,8 | 62 | |
| 400/690 | 3EL112M2C | 4,00 | 2915 | 7,28 | 13,1 | 0,90 | 88,1 | 88,8 | 88,2 | 7,5 | 2,6 | 3,9 | 0,00618 | 29,4 | 65 | |
| | 3EL132S2B | 5,50 | 2945 | 9,90 | 17,8 | 0,90 | 89,2 | 89,0 | 88,6 | 8,9 | 2,9 | 3,9 | 0,01732 | 45,7 | 67 | |
| | 3EL132S2C | 7,50 | 2945 | 13,2 | 24,3 | 0,91 | 90,1 | 90,5 | 89,7 | 8,4 | 2,6 | 4,0 | 0,02104 | 52,0 | 67 | |
| | 3EL160M2B | 11,0 | 2950 | 19,7 | 35,6 | 0,88 | 91,2 | 91,0 | 90,5 | 8,5 | 2,6 | 3,9 | 0,03318 | 79,7 | 69 | |
| | 3EL160M2C | 15,0 | 2950 | 26,5 | 48,6 | 0,89 | 91,9 | 92,1 | 91,6 | 8,9 | 3,1 | 4,2 | 0,03913 | 87,8 | 69 | |
| | 3EL160L2D | 18,5 | 2945 | 31,7 | 60,0 | 0,91 | 92,4 | 92,7 | 92,3 | 8,9 | 3,1 | 4,2 | 0,04409 | 95,2 | 69 | |
| | 3EL180M2B | 22,0 | 2957 | 38,1 | 71,1 | 0,90 | 92,7 | 92,9 | 92,0 | 8,6 | 3,1 | 3,9 | 0,06299 | 131 | 70 | |
| | 3EL200L2B | 30,0 | 2965 | 52,0 | 96,6 | 0,89 | 93,6 | 93,8 | 93,6 | 8,6 | 3,2 | 3,5 | 0,16168 | 181 | 72 | |
| | 3EL200L2C | 37,0 | 2965 | 63,3 | 119 | 0,90 | 93,7 | 94,1 | 93,8 | 8,6 | 3,2 | 3,4 | 0,17458 | 191 | 72 | |
| | 3EG225M2C | 45,0 | 2970 | 76,8 | 145 | 0,90 | 94,0 | 94,4 | 94,2 | 8,6 | 3,3 | 3,1 | 0,25353 | 335 | 74 | |
| | 3EG250M2C | 55,0 | 2970 | 93,3 | 177 | 0,90 | 94,4 | 94,8 | 94,5 | 8,6 | 3,3 | 3,4 | 0,38000 | 425 | 75 | |

Our UL approved motors have the  logo on their nameplates.



Electrical Characteristics

Duty Cycle : S1 (Continuous Operation)
 Insulation Class : F (155°C)
 Temperature Raise : B (80°K)

400V 50Hz 1500 d/d



| Voltage (V) | Type | Rated Values | | | | | | | | Starting Values | | Break Down Torque | Moment of Inertia | B3 Motor Weight | Sound Pressure Level |
|-------------|-----------|--------------|-------|---------|--------|--------------|---------------------|------|------|--------------------------------|--------------------------------|-------------------|-------------------|-----------------|----------------------|
| | | Power | Speed | Current | Torque | Power Factor | Efficiency % η | | | Current | Torque | | | | |
| | | kW | rpm | A | Nm | Cos ϕ | 4/4 | 3/4 | 1/2 | I _A /I _N | M _A /M _N | | | | |
| 230/400 | 3EL063M4B | 0,12 | 1405 | 0,37 | 0,82 | 0,70 | 66,0 | 64,9 | 58,2 | 3,7 | 2,3 | 2,7 | 0,00018 | 4,10 | 42 |
| | 3EL063M4C | 0,18 | 1405 | 0,52 | 1,22 | 0,71 | 69,9 | 68,8 | 63,6 | 3,8 | 2,3 | 2,8 | 0,00022 | 4,50 | 42 |
| | 3EL071M4C | 0,25 | 1435 | 0,67 | 1,66 | 0,71 | 76,0 | 75,4 | 71,5 | 5,4 | 2,1 | 2,8 | 0,00082 | 7,10 | 45 |
| | 3EL071M4D | 0,37 | 1435 | 0,97 | 2,46 | 0,70 | 78,5 | 78,2 | 75,0 | 5,5 | 2,2 | 2,9 | 0,00093 | 7,80 | 45 |
| | 3EL080M4C | 0,55 | 1450 | 1,34 | 3,62 | 0,73 | 80,8 | 80,4 | 77,0 | 5,9 | 2,1 | 3,0 | 0,00200 | 10,5 | 50 |
| | 3EL080M4D | 0,75 | 1450 | 1,77 | 4,94 | 0,74 | 82,5 | 82,3 | 80,0 | 6,2 | 2,5 | 3,1 | 0,00227 | 11,6 | 50 |
| | 3EL090S4C | 1,10 | 1450 | 2,51 | 7,25 | 0,75 | 84,5 | 84,3 | 82,0 | 7,0 | 2,6 | 3,4 | 0,00355 | 16,3 | 51 |
| | 3EL090L4D | 1,50 | 1445 | 3,30 | 9,91 | 0,77 | 85,3 | 85,2 | 83,0 | 7,2 | 2,8 | 3,4 | 0,00411 | 18,0 | 51 |
| | 3EL100L4C | 2,20 | 1450 | 4,65 | 14,5 | 0,79 | 86,7 | 87,2 | 86,0 | 7,2 | 2,8 | 3,6 | 0,00775 | 24,4 | 53 |
| | 3EL100L4D | 3,00 | 1450 | 6,26 | 19,8 | 0,79 | 87,7 | 88,0 | 87,0 | 7,2 | 2,8 | 3,6 | 0,00888 | 27,0 | 53 |
| 400/690 | 3EL112M4D | 4,00 | 1460 | 8,05 | 26,2 | 0,81 | 88,6 | 88,4 | 87,5 | 7,4 | 2,8 | 3,8 | 0,01437 | 32,6 | 58 |
| | 3EL132S4C | 5,50 | 1465 | 10,9 | 36,0 | 0,81 | 89,6 | 90,2 | 90,0 | 7,0 | 3,0 | 3,3 | 0,03059 | 53,4 | 61 |
| | 3EL132M4D | 7,50 | 1465 | 14,8 | 48,9 | 0,81 | 90,4 | 90,4 | 89,4 | 7,8 | 3,2 | 3,4 | 0,03418 | 56,6 | 61 |
| | 3EL160M4C | 11,0 | 1465 | 21,0 | 71,7 | 0,83 | 91,5 | 92,1 | 91,7 | 7,6 | 2,8 | 3,3 | 0,07011 | 89,2 | 63 |
| | 3EL160L4E | 15,0 | 1465 | 28,7 | 97,8 | 0,82 | 92,1 | 92,4 | 91,9 | 7,8 | 2,8 | 3,5 | 0,08579 | 97,5 | 63 |
| | 3EL180M4C | 18,5 | 1475 | 35,0 | 120 | 0,82 | 92,6 | 93,2 | 92,9 | 7,7 | 3,0 | 3,3 | 0,12901 | 128 | 64 |
| | 3EL180L4D | 22,0 | 1470 | 41,4 | 143 | 0,82 | 93,0 | 93,7 | 93,7 | 8,0 | 3,0 | 3,4 | 0,14667 | 141 | 64 |
| | 3EL200L4D | 30,0 | 1475 | 54,5 | 194 | 0,85 | 93,6 | 94,1 | 94,0 | 8,0 | 3,0 | 3,4 | 0,28413 | 193 | 65 |
| | 3EG225S4C | 37,0 | 1478 | 65,7 | 239 | 0,87 | 93,9 | 94,5 | 94,5 | 8,3 | 3,2 | 3,3 | 0,38229 | 320 | 66 |
| | 3EG225M4D | 45,0 | 1477 | 80,0 | 291 | 0,86 | 94,2 | 94,7 | 94,7 | 8,6 | 3,3 | 3,2 | 0,44100 | 350 | 67 |
| | 3EG250M4D | 55,0 | 1482 | 95,3 | 354 | 0,88 | 94,6 | 95,1 | 95,2 | 8,7 | 3,3 | 3,2 | 0,73000 | 460 | 68 |

Our UL approved motors have the  logo on their nameplates.

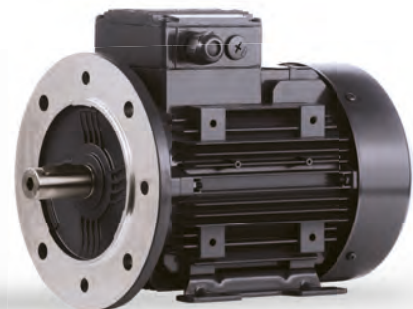

Electrical Characteristics

400V 50Hz 1000 d/d

Duty Cycle : S1 (Continuous Operation)
 Insulation Class : F (155°C)
 Temperature Raise : B (80°K)



| Voltage (V) | Type | Rated Values | | | | | | | | Starting Values | | Break Down Torque | Moment of Inertia | B3 Motor Weight | Sound Pressure Level |
|-------------|-----------|--------------|-------|---------|--------|--------------|---------------------|------|------|--------------------------------|--------------------------------|-------------------|-------------------|-----------------|----------------------|
| | | Power | Speed | Current | Torque | Power Factor | Efficiency % η | | | Current | Torque | | | | |
| | | kW | rpm | A | Nm | Cos ϕ | 4/4 | 3/4 | 1/2 | I _A /I _N | M _A /M _N | | | | |
| 230/400 | 3EL071M6C | 0,18 | 930 | 0,55 | 1,85 | 0,69 | 68,0 | 67,4 | 62,6 | 3,6 | 2,0 | 2,4 | 0,00096 | 6,80 | 41 |
| | 3EL071M6D | 0,25 | 930 | 0,77 | 2,57 | 0,67 | 70,0 | 69,7 | 66,0 | 3,6 | 2,2 | 2,5 | 0,00116 | 7,50 | 41 |
| | 3EL080M6B | 0,37 | 930 | 1,03 | 3,80 | 0,70 | 74,0 | 73,8 | 70,0 | 4,4 | 2,1 | 2,6 | 0,00202 | 9,90 | 43 |
| | 3EL080M6C | 0,55 | 935 | 1,47 | 5,62 | 0,70 | 77,2 | 77,3 | 74,4 | 4,3 | 2,2 | 2,7 | 0,00228 | 11,0 | 43 |
| | 3EL090S6B | 0,75 | 945 | 1,96 | 7,58 | 0,70 | 78,9 | 79,2 | 77,6 | 4,7 | 2,2 | 2,7 | 0,00354 | 16,0 | 46 |
| | 3EL090L6C | 1,10 | 940 | 2,75 | 11,2 | 0,71 | 81,0 | 80,8 | 79,4 | 5,0 | 2,2 | 2,7 | 0,00428 | 16,8 | 46 |
| | 3EL100L6B | 1,50 | 955 | 3,50 | 15,0 | 0,75 | 82,5 | 82,7 | 81,4 | 5,3 | 2,1 | 2,8 | 0,00821 | 22,5 | 50 |
| | 3EL112M6B | 2,20 | 960 | 4,95 | 21,9 | 0,76 | 84,3 | 84,5 | 83,5 | 5,5 | 2,2 | 3,0 | 0,01319 | 29,6 | 56 |
| 400/690 | 3EL132S6B | 3,00 | 970 | 6,55 | 29,4 | 0,77 | 85,6 | 85,5 | 84,5 | 6,2 | 2,1 | 3,0 | 0,03051 | 46,7 | 58 |
| | 3EL132M6C | 4,00 | 970 | 8,52 | 39,4 | 0,78 | 86,8 | 87,0 | 85,5 | 6,2 | 2,2 | 2,9 | 0,03493 | 50,9 | 58 |
| | 3EL132M6D | 5,50 | 965 | 11,6 | 54,4 | 0,78 | 88,0 | 88,9 | 88,5 | 6,2 | 2,2 | 2,8 | 0,03934 | 57,3 | 58 |
| | 3EL160M6D | 7,50 | 972 | 15,6 | 73,7 | 0,78 | 89,1 | 89,4 | 88,4 | 6,3 | 2,6 | 3,0 | 0,07870 | 96,0 | 61 |
| | 3EL160L6E | 11,0 | 972 | 23,1 | 108 | 0,76 | 90,3 | 90,9 | 90,5 | 6,6 | 2,9 | 3,1 | 0,08580 | 104 | 62 |
| | 3EL180L6E | 15,0 | 975 | 30,8 | 147 | 0,77 | 91,2 | 91,6 | 91,0 | 6,7 | 2,9 | 3,1 | 0,15264 | 141 | 63 |
| | 3EL200L6C | 18,5 | 977 | 36,4 | 181 | 0,80 | 91,7 | 91,8 | 91,8 | 6,1 | 2,6 | 2,6 | 0,36100 | 164 | 64 |
| | 3EL200L6D | 22,0 | 978 | 42,5 | 215 | 0,81 | 92,2 | 92,9 | 93,0 | 6,2 | 2,6 | 2,6 | 0,39355 | 180 | 64 |
| | 3EG225S6C | 30,0 | 985 | 57,6 | 291 | 0,81 | 92,9 | 92,9 | 92,6 | 6,6 | 2,9 | 2,7 | 0,60000 | 340 | 65 |
| | 3EG250M6C | 37,0 | 988 | 68,8 | 358 | 0,83 | 93,4 | 93,6 | 93,5 | 7,3 | 2,9 | 2,8 | 0,82000 | 435 | 65 |
| | 3EG280S6B | 45,0 | 989 | 83,5 | 435 | 0,83 | 93,7 | 93,9 | 93,2 | 6,8 | 2,9 | 2,8 | 1,45000 | 590 | 65 |
| | 3EG280M6C | 55,0 | 989 | 102 | 531 | 0,83 | 94,1 | 94,4 | 93,5 | 6,9 | 2,9 | 2,8 | 1,65000 | 620 | 65 |

Our UL approved motors have the  logo on their nameplates.



Electrical Characteristics

400V 50Hz 3000 d/d

Duty Cycle : S1 (Continuous Operation)
 Insulation Class : F (155°C)
 Temperature Raise : B (80°K)

Compact **IE3**

| Voltage (V) | Type | Rated Values | | | | | | | | Starting Values | | Break Down Torque | Moment of Inertia | B3 Motor Weight | Sound Pressure Level |
|-------------|-------------|--------------|-------|---------|--------|--------------|---------------------|------|------|--------------------------------|--------------------------------|-------------------|-------------------|-----------------|----------------------|
| | | Power | Speed | Current | Torque | Power Factor | Efficiency % η | | | Current | Torque | | | | |
| | | kW | rpm | A | Nm | Cos ϕ | 4/4 | 3/4 | 1/2 | I _A /I _N | M _A /M _N | | | | |
| 230/400 | 3EC071M2C | 0,75 | 2810 | 1,66 | 2,55 | 0,81 | 80,7 | 81,0 | 80,3 | 5,0 | 2,6 | 3,1 | 0,00046 | 7,20 | 55 |
| | 3EC080M2D | 1,50 | 2850 | 3,06 | 5,03 | 0,84 | 84,2 | 84,8 | 84,2 | 6,4 | 3,2 | 3,6 | 0,00135 | 11,8 | 59 |
| | 3EC090L2D | 3,00 | 2875 | 5,92 | 9,96 | 0,84 | 87,1 | 87,7 | 87,5 | 7,3 | 3,2 | 3,8 | 0,00234 | 19,2 | 63 |
| 400/690 | 3EC100L2D | 4,00 | 2900 | 7,53 | 13,2 | 0,87 | 88,1 | 89,1 | 88,6 | 8,4 | 3,2 | 4,2 | 0,00503 | 25,4 | 66 |
| | 3EC112M2D | 5,50 | 2940 | 10,4 | 17,9 | 0,86 | 90,0 | 90,3 | 89,3 | 8,9 | 3,2 | 4,4 | 0,00734 | 32,0 | 68 |
| | 3EC112M2E** | 7,50 | 2930 | 14,0 | 24,4 | 0,86 | 90,1 | 90,6 | 90,0 | 9,2 | 3,3 | 4,4 | 0,00920 | 40,5 | 69 |
| | 3EC132M2D | 11,0 | 2940 | 19,8 | 35,7 | 0,88 | 91,2 | 91,9 | 91,5 | 8,9 | 3,2 | 4,4 | 0,02290 | 55,5 | 69 |
| | 3EC132M2F** | 15,0 | 2945 | 26,9 | 48,6 | 0,88 | 91,9 | 92,6 | 92,4 | 9,4 | 3,6 | 4,6 | 0,02910 | 69,0 | 70 |
| | 3EC160L2E | 22,0 | 2940 | 38,1 | 71,5 | 0,90 | 92,7 | 93,2 | 92,8 | 8,9 | 3,3 | 4,4 | 0,04710 | 114 | 70 |
| | 3EC180M2C | 30,0 | 2955 | 51,0 | 96,9 | 0,91 | 93,3 | 93,9 | 93,8 | 9,0 | 3,5 | 4,4 | 0,08800 | 150 | 74 |
| | 3EC200L2D | 45,0 | 2970 | 78,1 | 145 | 0,89 | 94,0 | 94,9 | 94,7 | 9,0 | 3,6 | 3,5 | 0,18700 | 200 | 77 |
| | 3ED225M2C | 55,0 | 2970 | 94,6 | 177 | 0,89 | 94,3 | 94,8 | 94,6 | 9,0 | 3,6 | 3,5 | 0,25300 | 335 | 78 |
| 3ED315L2F* | 250 | 2982 | 414 | 801 | 0,91 | 95,8 | 95,6 | 95,2 | 8,7 | 3,0 | 3,3 | 2,80000 | 1410 | 81 | |

400V 50Hz 1500 d/d

Duty Cycle : S1 (Continuous Operation)
 Insulation Class : F (155°C)
 Temperature Raise : B (80°K)

Compact **IE3**

| Voltage (V) | Type | Rated Values | | | | | | | | Starting Values | | Break Down Torque | Moment of Inertia | B3 Motor Weight | Sound Pressure Level |
|-------------|-------------|--------------|-------|---------|--------|--------------|---------------------|------|------|--------------------------------|--------------------------------|-------------------|-------------------|-----------------|----------------------|
| | | Power | Speed | Current | Torque | Power Factor | Efficiency % η | | | Current | Torque | | | | |
| | | kW | rpm | A | Nm | Cos ϕ | 4/4 | 3/4 | 1/2 | I _A /I _N | M _A /M _N | | | | |
| 400/690 | 3EC112M4F** | 5,50 | 1455 | 11,1 | 36,1 | 0,80 | 89,6 | 90,2 | 89,6 | 7,4 | 3,1 | 3,8 | 0,01620 | 38,6 | 64 |
| | 3EC132M4E | 9,00 | 1460 | 17,9 | 58,9 | 0,80 | 90,8 | 91,6 | 91,2 | 7,4 | 3,1 | 3,4 | 0,03600 | 61,4 | 64 |
| | 3EC132M4F** | 11,0 | 1465 | 21,7 | 71,7 | 0,80 | 91,4 | 91,6 | 91,5 | 7,4 | 3,1 | 3,4 | 0,04320 | 72,5 | 64 |
| | 3EC160L4F | 18,5 | 1465 | 35,8 | 121 | 0,81 | 92,6 | 93,1 | 92,8 | 7,4 | 3,1 | 3,4 | 0,09300 | 113 | 65 |
| | 3EC180L4E | 30,0 | 1470 | 58,0 | 195 | 0,80 | 93,6 | 94,1 | 93,9 | 7,8 | 3,2 | 3,4 | 0,16400 | 164 | 66 |
| | 3EC200L4D | 37,0 | 1475 | 66,1 | 240 | 0,86 | 93,9 | 94,7 | 94,9 | 7,8 | 3,2 | 3,4 | 0,28400 | 194 | 68 |
| | 3ED225M4E | 55,0 | 1480 | 97,7 | 355 | 0,86 | 94,6 | 95,2 | 95,4 | 8,0 | 3,6 | 3,5 | 0,50200 | 370 | 70 |
| | 3ED315L4G* | 250 | 1492 | 442 | 1600 | 0,85 | 96,0 | 96,1 | 95,6 | 8,1 | 3,0 | 3,4 | 5,47000 | 1530 | 75 |

Motors marked with * have Class H insulation and Class F temperature rise values.
 Motors marked with ** do not have a symmetrical frame structure.

THREE-PHASE MOTORS



E/E IE4 Motors



Electrical Characteristics

400V 50Hz 3000 d/d

Duty Cycle : S1 (Continuous Operation)
 Insulation Class : F (155°C)
 Temperature Raise : B (80°K)



| Voltage (V) | Type | Rated Values | | | | | | | | Starting Values | | Break Down Torque | Moment of Inertia | B3 Motor Weight | Sound Pressure Level |
|-------------|-----------|--------------|-------|---------|--------|--------------|---------------------|------|------|--------------------------------|--------------------------------|-------------------|-------------------|-----------------|----------------------|
| | | Power | Speed | Current | Torque | Power Factor | Efficiency % η | | | Current | Torque | | | | |
| | | kW | rpm | A | Nm | Cos ϕ | 4/4 | 3/4 | 1/2 | I _A /I _N | M _A /M _N | | | | |
| 230/400 | 4EL071M2B | 0,37 | 2825 | 0,83 | 1,25 | 0,82 | 78,1 | 78,3 | 76,5 | 5,7 | 2,8 | 3,2 | 0,00037 | 6,50 | 58 |
| | 4EL071M2C | 0,55 | 2825 | 1,17 | 1,86 | 0,83 | 81,5 | 81,9 | 79,5 | 6,2 | 2,9 | 3,5 | 0,00046 | 7,50 | 58 |
| | 4EL080M2C | 0,75 | 2875 | 1,56 | 2,49 | 0,83 | 83,5 | 84,0 | 81,0 | 6,8 | 2,9 | 3,5 | 0,00124 | 11,0 | 59 |
| | 4EL080M2D | 1,10 | 2880 | 2,19 | 3,65 | 0,85 | 85,2 | 85,5 | 84,9 | 7,5 | 2,9 | 3,7 | 0,00135 | 12,0 | 59 |
| | 4EL090S2C | 1,50 | 2900 | 2,95 | 4,94 | 0,85 | 86,5 | 86,9 | 85,7 | 7,8 | 2,9 | 3,7 | 0,00221 | 17,2 | 64 |
| | 4EL090L2D | 2,20 | 2900 | 4,20 | 7,24 | 0,86 | 88,0 | 88,5 | 87,6 | 8,2 | 3,0 | 3,8 | 0,00234 | 20,0 | 64 |
| 4EL100L2D | 3,00 | 2910 | 5,50 | 9,85 | 0,88 | 89,1 | 89,5 | 88,5 | 8,5 | 3,0 | 4,0 | 0,00503 | 25,9 | 67 | |
| 400/690 | 4EL112M2D | 4,00 | 2940 | 7,30 | 13,0 | 0,88 | 90,0 | 90,3 | 89,7 | 8,7 | 3,0 | 4,2 | 0,00734 | 32,2 | 70 |
| | 4EL132S2C | 5,50 | 2945 | 9,60 | 17,8 | 0,91 | 90,9 | 90,9 | 90,0 | 8,9 | 3,2 | 4,2 | 0,02104 | 52,5 | 72 |
| | 4EL132S2D | 7,50 | 2945 | 13,0 | 24,5 | 0,91 | 91,7 | 92,2 | 91,8 | 8,5 | 3,2 | 4,2 | 0,02290 | 55,6 | 72 |
| | 4EL160M2C | 11,0 | 2950 | 18,9 | 35,6 | 0,91 | 92,6 | 92,7 | 91,2 | 8,5 | 3,3 | 4,3 | 0,03913 | 89,0 | 74 |
| | 4EL160M2D | 15,0 | 2950 | 25,6 | 48,6 | 0,91 | 93,3 | 93,6 | 92,8 | 8,5 | 3,3 | 4,3 | 0,04409 | 96,8 | 74 |
| | 4EL160L2E | 18,5 | 2955 | 31,4 | 59,8 | 0,91 | 93,7 | 93,8 | 92,9 | 8,7 | 3,2 | 4,3 | 0,05000 | 114 | 74 |
| | 4EL180M2C | 22,0 | 2960 | 37,2 | 71,1 | 0,91 | 94,0 | 94,4 | 93,5 | 8,9 | 3,0 | 4,0 | 0,07000 | 158 | 74 |
| | 4EL200L2C | 30,0 | 2970 | 51,0 | 96,5 | 0,90 | 94,5 | 94,7 | 94,0 | 8,3 | 3,2 | 3,7 | 0,17500 | 215 | 74 |
| | 4EL200L2D | 37,0 | 2970 | 63,3 | 120 | 0,89 | 94,8 | 95,0 | 94,2 | 8,3 | 3,2 | 4,0 | 0,20000 | 235 | 74 |
| | 4EG225M2D | 45,0 | 2975 | 76,0 | 145 | 0,90 | 95,0 | 95,2 | 94,9 | 9,0 | 3,4 | 4,2 | 0,29000 | 355 | 74 |
| | 4EG250M2D | 55,0 | 2975 | 92,6 | 177 | 0,90 | 95,3 | 95,5 | 94,9 | 8,2 | 3,4 | 3,7 | 0,52000 | 445 | 74 |
| | 4EG280S2C | 75,0 | 2982 | 126 | 240 | 0,90 | 95,6 | 95,6 | 95,2 | 7,7 | 2,7 | 3,2 | 0,98000 | 620 | 76 |
| | 4EG280M2D | 90,0 | 2985 | 151 | 288 | 0,90 | 95,8 | 95,9 | 95,0 | 7,7 | 2,8 | 3,5 | 1,10000 | 640 | 77 |
| | 4EG315S2C | 110 | 2985 | 184 | 352 | 0,90 | 96,0 | 96,0 | 95,7 | 7,8 | 3,1 | 4,0 | 1,60000 | 1110 | 77 |
| | 4EG315M2D | 132 | 2986 | 220 | 422 | 0,90 | 96,2 | 96,3 | 96,0 | 8,0 | 3,1 | 4,0 | 2,00000 | 1070 | 77 |
| | 4EG315L2E | 160 | 2986 | 267 | 512 | 0,90 | 96,3 | 96,5 | 96,0 | 8,0 | 3,2 | 4,0 | 2,20000 | 1230 | 78 |
| 4EG315L2F | 200 | 2987 | 332 | 639 | 0,90 | 96,5 | 96,7 | 96,2 | 8,1 | 3,2 | 4,0 | 2,70000 | 1340 | 78 | |

Our UL approved motors have the  logo on their nameplates.



Electrical Characteristics

Duty Cycle : S1 (Continuous Operation)
 Insulation Class : F (155°C)
 Temperature Raise : B (80°K)

400V 50Hz 1500 d/d



| Voltage (V) | Type | Rated Values | | | | | | | | Starting Values | | Break Down Torque | Moment of Inertia | B3 Motor Weight | Sound Pressure Level |
|-------------|------------|--------------|-------|---------|--------|--------------|---------------------|------|------|--------------------------------|--------------------------------|-------------------|-------------------|-----------------|----------------------|
| | | Power | Speed | Current | Torque | Power Factor | Efficiency % η | | | Current | Torque | | | | |
| | | kW | rpm | A | Nm | Cos ϕ | 4/4 | 3/4 | 1/2 | I _A /I _N | M _A /M _N | | | | |
| 400/690 | 4EL132S4D | 5,50 | 1470 | 11,1 | 35,7 | 0,78 | 91,9 | 91,8 | 90,6 | 7,7 | 3,8 | 3,7 | 0,03418 | 56,7 | 61 |
| | 4EL132M4F* | 7,50 | 1470 | 14,6 | 48,7 | 0,80 | 92,6 | 92,7 | 91,5 | 7,7 | 3,8 | 4,0 | 0,04316 | 72,8 | 62 |
| | 4EL160M4E | 11,0 | 1470 | 21,0 | 71,5 | 0,81 | 93,3 | 93,5 | 93,3 | 7,7 | 3,0 | 3,6 | 0,08600 | 99,5 | 64 |
| | 4EL160L4F | 15,0 | 1475 | 28,9 | 97,5 | 0,80 | 93,9 | 94,1 | 93,8 | 8,7 | 3,7 | 4,3 | 0,12000 | 112 | 64 |
| | 4EL180M4D | 18,5 | 1475 | 34,6 | 120 | 0,82 | 94,2 | 94,4 | 94,0 | 8,0 | 3,1 | 3,5 | 0,14700 | 142 | 64 |
| | 4EL180L4E | 22,0 | 1475 | 41,0 | 142 | 0,82 | 94,5 | 94,7 | 94,2 | 8,2 | 3,2 | 3,8 | 0,17000 | 168 | 64 |
| | 4EL200L4E | 30,0 | 1480 | 53,0 | 194 | 0,86 | 94,9 | 95,3 | 95,2 | 8,3 | 3,3 | 3,8 | 0,35000 | 235 | 64 |
| | 4EG225S4D | 37,0 | 1480 | 65,0 | 239 | 0,86 | 95,2 | 95,7 | 95,0 | 8,1 | 3,3 | 3,3 | 0,44100 | 350 | 70 |
| | 4EG225M4E | 45,0 | 1480 | 79,2 | 290 | 0,86 | 95,4 | 95,6 | 95,6 | 8,2 | 3,5 | 3,3 | 0,52000 | 370 | 70 |
| | 4EG250M4E | 55,0 | 1485 | 94,3 | 354 | 0,88 | 95,7 | 96,0 | 96,0 | 8,5 | 3,3 | 3,4 | 1,05000 | 490 | 70 |
| | 4EG280S4D | 75,0 | 1487 | 127 | 482 | 0,89 | 96,0 | 96,3 | 96,2 | 8,7 | 3,0 | 3,2 | 1,50000 | 670 | 70 |
| | 4EG280M4E | 90,0 | 1488 | 152 | 578 | 0,89 | 96,1 | 96,3 | 96,3 | 8,9 | 3,1 | 3,2 | 1,95000 | 720 | 71 |
| | 4EG315S4D | 110 | 1491 | 187 | 705 | 0,88 | 96,3 | 96,5 | 96,0 | 8,9 | 2,8 | 3,3 | 2,80000 | 1200 | 73 |
| | 4EG315M4E | 132 | 1492 | 225 | 845 | 0,88 | 96,4 | 96,7 | 96,2 | 8,9 | 2,9 | 3,3 | 3,30000 | 1270 | 73 |
| | 4EG315L4F | 160 | 1492 | 272 | 1024 | 0,88 | 96,6 | 96,9 | 96,5 | 8,9 | 3,1 | 3,4 | 4,40000 | 1370 | 76 |
| 4EG315L4G | 200 | 1492 | 339 | 1280 | 0,88 | 96,7 | 97,0 | 96,6 | 8,8 | 3,3 | 3,5 | 5,20000 | 1520 | 76 | |

Our UL approved motors have the  logo on their nameplates.

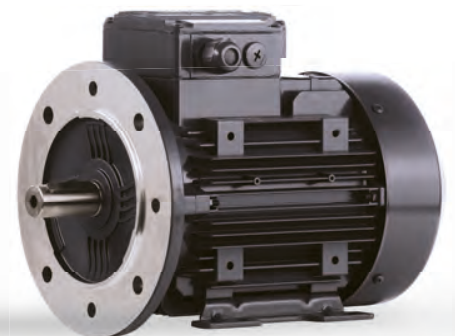

Motors marked with ** do not have a symmetrical frame structure.

Electrical Characteristics

400V 50Hz 1000 d/d

Duty Cycle : S1 (Continuous Operation)
 Insulation Class : F (155°C)
 Temperature Raise : B (80°K)



| Voltage (V) | Type | Rated Values | | | | | | | | Starting Values | | Break Down Torque | Moment of Inertia | B3 Motor Weight | Sound Pressure Level |
|-------------|-----------|--------------|-------|---------|--------|--------------|---------------------|------|------|--------------------------------|--------------------------------|-------------------|-------------------|-----------------|----------------------|
| | | Power | Speed | Current | Torque | Power Factor | Efficiency % η | | | Current | Torque | | | | |
| | | kW | rpm | A | Nm | Cos ϕ | 4/4 | 3/4 | 1/2 | I _A /I _N | M _A /M _N | | | | |
| 400/690 | 4EG315S6C | 75,0 | 994 | 133 | 721 | 0,85 | 95,4 | 95,5 | 95,2 | 8,80 | 2,80 | 3,50 | 3,50000 | 1215 | 67 |
| | 4EG315M6D | 90,0 | 994 | 160 | 865 | 0,85 | 95,6 | 95,7 | 95,4 | 8,80 | 2,80 | 3,70 | 3,80000 | 1250 | 67 |
| | 4EG315L6E | 110 | 995 | 193 | 1056 | 0,86 | 95,8 | 96,1 | 95,7 | 8,60 | 2,80 | 3,70 | 4,50000 | 1280 | 68 |
| | 4EG315L6F | 132 | 995 | 231 | 1267 | 0,86 | 96,0 | 96,2 | 95,8 | 8,50 | 2,80 | 3,70 | 5,20000 | 1350 | 68 |
| | 4EG315L6G | 160 | 995 | 280 | 1536 | 0,86 | 96,2 | 96,4 | 96,3 | 7,70 | 2,90 | 3,80 | 5,55000 | 1446 | 70 |

Our UL approved motors have the  logo on their nameplates.



THREE-PHASE MOTORS



Dimensions

B3 Construction Type

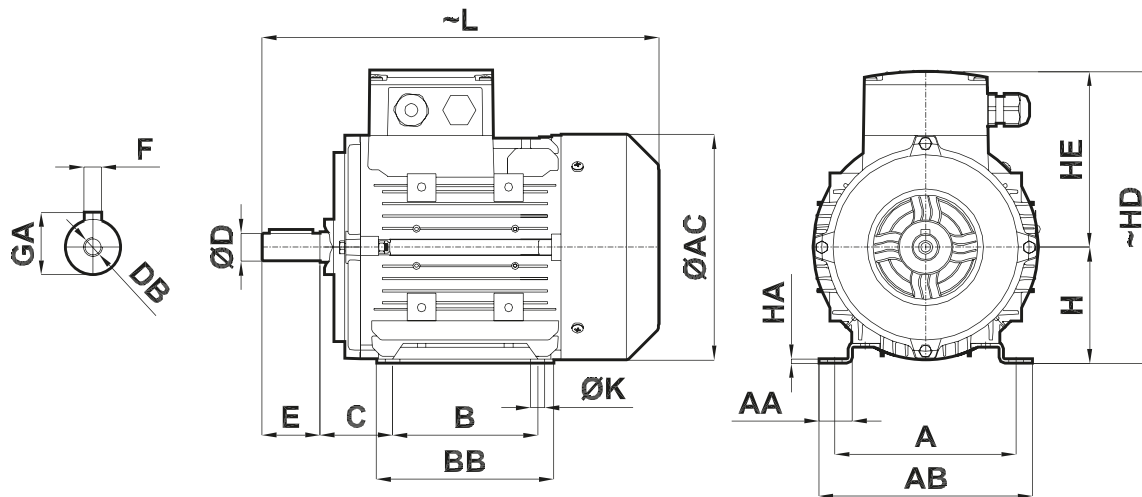

| Frame Size | Efficiency Class | Number of Poles | D ^[1] | E | L | AC | H ^[2] | HE | HD | F | GA | DB | C | ØK | B | BB | HA | AA | A | AB |
|---------------------|------------------|-----------------|------------------|-----|------|-----|------------------|-------|-------|----|------|-----|-----|------|-----|-----|----|-----|-----|-----|
| 063M | IE2/IE3 | 2-4 | 11 | 23 | 213 | 119 | 63 | 101 | 164 | 4 | 12,5 | M4 | 40 | 7 | 80 | 104 | 3 | 18 | 100 | 115 |
| 071M | IE2/IE3/IE4 | 2-4-6-8 | 14 | 30 | 242 | 137 | 71 | 118 | 189 | 5 | 16 | M5 | 45 | 7 | 90 | 110 | 3 | 19 | 112 | 128 |
| 080M | IE2/IE3/IE4 | 2-4-6-8 | 19 | 40 | 274 | 155 | 80 | 127 | 207 | 6 | 21,5 | M6 | 50 | 10 | 100 | 122 | 3 | 25 | 125 | 148 |
| 090S | IE3/IE4 | 2-4-6-8 | 24 | 50 | 325 | 176 | 90 | 136 | 226 | 8 | 27 | M8 | 56 | 10 | 100 | 151 | 4 | 27 | 140 | 167 |
| 090L | IE3/IE4 | 2-4-6-8 | 24 | 50 | 325 | 176 | 90 | 136 | 226 | 8 | 27 | M8 | 56 | 10 | 125 | 151 | 4 | 27 | 140 | 167 |
| 100L | IE3/IE4 | 2-4-6-8 | 28 | 60 | 369 | 193 | 100 | 149 | 249 | 8 | 31 | M10 | 63 | 12 | 140 | 170 | 4 | 31 | 160 | 191 |
| 112M | IE3/IE3C/IE4 | 2-4-6-8 | 28 | 60 | 392 | 215 | 112 | 161 | 273 | 8 | 31 | M10 | 70 | 12 | 140 | 177 | 4 | 36 | 190 | 217 |
| 112M ^[3] | IE3C | 2-4 | 28 | 60 | 430 | 215 | 112 | 161 | 273 | 8 | 31 | M10 | 70 | 12 | 140 | 177 | 4 | 36 | 190 | 217 |
| 132S | IE3/IE4 | 2-4-6-8 | 38 | 80 | 495 | 257 | 132 | 182 | 314 | 10 | 41 | M12 | 89 | 12 | 140 | 212 | 5 | 34 | 216 | 246 |
| 132M | IE3/IE3C/IE4 | 2-4-6-8 | 38 | 80 | 495 | 257 | 132 | 182 | 314 | 10 | 41 | M12 | 89 | 12 | 178 | 212 | 5 | 34 | 216 | 246 |
| 132M ^[4] | IE3C/IE4 | 2-4 | 38 | 80 | 543 | 257 | 132 | 182 | 314 | 10 | 41 | M12 | 89 | 12 | 178 | 212 | 5 | 34 | 216 | 246 |
| 160M | IE3/IE4 | 2-4-6-8 | 42 | 110 | 605 | 316 | 160 | 226 | 386 | 12 | 45 | M16 | 108 | 14,5 | 210 | 328 | 15 | 65 | 254 | 293 |
| 160L | IE3/IE4 | 2-4-6-8 | 42 | 110 | 605 | 316 | 160 | 226 | 386 | 12 | 45 | M16 | 108 | 14,5 | 254 | 328 | 15 | 65 | 254 | 293 |
| 180M | IE3/IE4 | 2-4-6-8 | 48 | 110 | 696 | 348 | 180 | 242 | 422 | 14 | 51,5 | M16 | 121 | 14,5 | 241 | 319 | 15 | 63 | 279 | 316 |
| 180L | IE3/IE4 | 2-4-6-8 | 48 | 110 | 696 | 348 | 180 | 242 | 422 | 14 | 51,5 | M16 | 121 | 14,5 | 279 | 319 | 15 | 63 | 279 | 316 |
| 200M | IE3/IE4 | 2-4-6-8 | 55 | 110 | 737 | 396 | 200 | 294 | 494 | 16 | 59 | M20 | 133 | 18,5 | 267 | 350 | 20 | 76 | 318 | 372 |
| 200L | IE3/IE4 | 2-4-6-8 | 55 | 110 | 737 | 396 | 200 | 294 | 494 | 16 | 59 | M20 | 133 | 18,5 | 305 | 350 | 20 | 76 | 318 | 372 |
| 225S | IE3/IE4 | 2 | 55 | 110 | 800 | 438 | 225 | 311,5 | 536,5 | 16 | 59 | M20 | 149 | 18,5 | 286 | 360 | 20 | 90 | 356 | 417 |
| | | 4-6-8 | 60 | 140 | 830 | | | | | 18 | 64 | | | | | | | | | |
| 225M | IE3/IE4 | 2 | 55 | 110 | 800 | 438 | 225 | 311,5 | 536,5 | 16 | 59 | M20 | 149 | 18,5 | 311 | 360 | 20 | 90 | 356 | 417 |
| | | 4-6-8 | 60 | 140 | 830 | | | | | 18 | 64 | | | | | | | | | |
| 250S | IE3/IE4 | 2 | 60 | 140 | 896 | 481 | 250 | 337 | 587 | 18 | 64 | M20 | 168 | 24 | 311 | 433 | 32 | 105 | 406 | 475 |
| | | 4-6-8 | 65 | 140 | 896 | | | | | 18 | 69 | | | | | | | | | |
| 250M | IE3/IE4 | 2 | 60 | 140 | 896 | 481 | 250 | 337 | 587 | 18 | 64 | M20 | 168 | 24 | 349 | 433 | 32 | 105 | 406 | 475 |
| | | 4-6-8 | 65 | 140 | 896 | | | | | 18 | 69 | | | | | | | | | |
| 280S | IE3/IE4 | 2 | 65 | 140 | 1012 | 547 | 280 | 402 | 682 | 18 | 69 | M20 | 190 | 24 | 368 | 500 | 35 | 105 | 457 | 531 |
| | | 4-6-8 | 75 | 140 | 1012 | | | | | 20 | 79,5 | | | | | | | | | |
| 280M | IE3/IE4 | 2 | 65 | 140 | 1012 | 547 | 280 | 402 | 682 | 18 | 69 | M20 | 190 | 24 | 419 | 500 | 35 | 105 | 457 | 531 |
| | | 4-6-8 | 75 | 140 | 1012 | | | | | 20 | 79,5 | | | | | | | | | |
| 315S | IE3/IE4 | 2 | 65 | 140 | 1242 | 622 | 315 | 499 | 814 | 18 | 69 | M20 | 216 | 28 | 406 | 636 | 33 | 157 | 508 | 626 |
| | | 4-6-8 | 80 | 170 | 1272 | | | | | 22 | 85 | | | | | | | | | |
| 315M | IE3/IE4 | 2 | 65 | 140 | 1242 | 622 | 315 | 499 | 814 | 18 | 69 | M20 | 216 | 28 | 457 | 636 | 33 | 157 | 508 | 626 |
| | | 4-6-8 | 80 | 170 | 1272 | | | | | 22 | 85 | | | | | | | | | |
| 315L | IE3/IE4 | 2 | 65 | 140 | 1389 | 622 | 315 | 499 | 814 | 18 | 69 | M20 | 216 | 28 | 508 | 800 | 35 | 145 | 508 | 623 |
| | | 4-6-8 | 90 | 170 | 1419 | | | | | 25 | 95 | | | | | | | | | |

[1] Tolerance "j6" up to 28mm, "k6" from 28mm to 48mm, "m6" over 48mm TS EN 50347

[2] Tolerance 063-250 "-0.5mm" / 280-315 "-1mm" TS EN 50347

[3] 7.50kW 2Pole IE3 Compact Motors / 5.50kW 4Pole IE3 Compact Motors

[4] 15.0kW 2Pole IE3 Compact / 11.0kW 4Pole IE3 Compact / 7.50kW 4Pole IE4 Motors

B5- B35 Construction Types

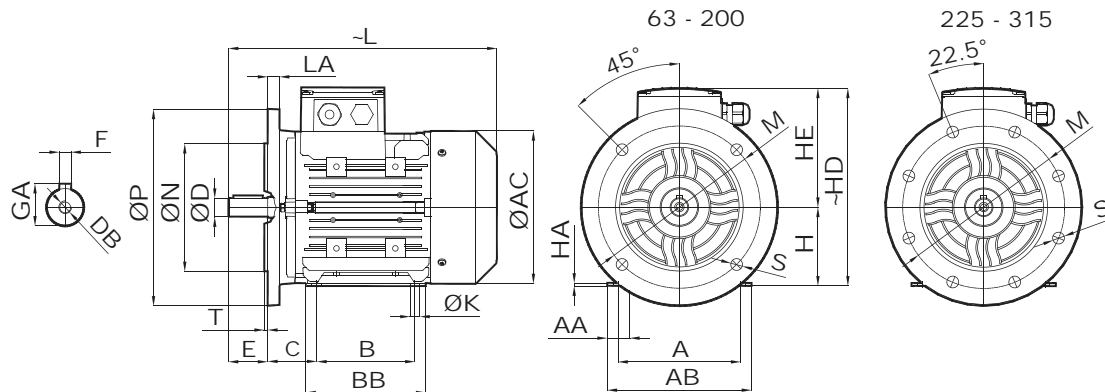

| Frame Size | Efficiency Class | Number of Poles | D ^[1] | E | N ^[2] | P | T | LA | L | AC | S | M | H ^[3] | HE | HD | F | GA | DB | C | ØK | B | BB | H _A | AA | A | AB |
|---------------------|------------------|-----------------|------------------|-----|------------------|-----|-----|----|------|-----|------|-----|------------------|-----|-----|----|------|-----|-----|------|-----|-----|----------------|-----|-----|-----|
| 063M | IE2/IE3 | 2-4 | 11 | 23 | 95 | 140 | 3 | 8 | 213 | 119 | 10 | 115 | 63 | 97 | 160 | 4 | 12,5 | M4 | 40 | 7 | 80 | 104 | 3 | 18 | 100 | 115 |
| 071M | IE2/IE3/IE4 | 2-4-6-8 | 14 | 30 | 110 | 160 | 3,5 | 8 | 242 | 137 | 10 | 130 | 71 | 112 | 183 | 5 | 16 | M5 | 45 | 7 | 90 | 110 | 3 | 19 | 112 | 128 |
| 080M | IE2/IE3/IE4 | 2-4-6-8 | 19 | 40 | 130 | 200 | 3,5 | 12 | 274 | 155 | 12 | 165 | 80 | 127 | 207 | 6 | 21,5 | M6 | 50 | 10 | 100 | 122 | 3 | 25 | 125 | 148 |
| 090S | IE3/IE4 | 2-4-6-8 | 24 | 50 | 130 | 200 | 3,5 | 12 | 325 | 176 | 12 | 165 | 90 | 136 | 226 | 8 | 27 | M8 | 56 | 10 | 100 | 151 | 4 | 27 | 140 | 167 |
| 090L | IE3/IE4 | 2-4-6-8 | 24 | 50 | 130 | 200 | 3,5 | 12 | 325 | 176 | 12 | 165 | 90 | 136 | 226 | 8 | 27 | M8 | 56 | 10 | 125 | 151 | 4 | 27 | 140 | 167 |
| 100L | IE3/IE4 | 2-4-6-8 | 28 | 60 | 180 | 250 | 4 | 15 | 369 | 193 | 14,5 | 215 | 100 | 148 | 248 | 8 | 31 | M10 | 63 | 12 | 140 | 170 | 4 | 31 | 160 | 191 |
| 112M | IE3/IE3C/IE4 | 2-4-6-8 | 28 | 60 | 180 | 250 | 4 | 15 | 392 | 215 | 14,5 | 215 | 112 | 161 | 273 | 8 | 31 | M10 | 70 | 12 | 140 | 177 | 4 | 36 | 190 | 217 |
| 112M ^[4] | IE3C | 2-4 | 28 | 60 | 180 | 250 | 4 | 15 | 430 | 215 | 14,5 | 215 | 112 | 161 | 273 | 8 | 31 | M10 | 70 | 12 | 140 | 177 | 4 | 36 | 190 | 217 |
| 132S | IE3/IE4 | 2-4-6-8 | 38 | 80 | 230 | 300 | 4 | 20 | 495 | 257 | 14,5 | 265 | 132 | 180 | 312 | 10 | 41 | M12 | 89 | 12 | 140 | 212 | 5 | 34 | 216 | 246 |
| 132M | IE3/IE3C/IE4 | 2-4-6-8 | 38 | 80 | 230 | 300 | 4 | 20 | 495 | 257 | 14,5 | 265 | 132 | 180 | 312 | 10 | 41 | M12 | 89 | 12 | 178 | 212 | 5 | 34 | 216 | 246 |
| 132M ^[5] | IE3C/IE4 | 2-4 | 38 | 80 | 230 | 300 | 4 | 20 | 543 | 257 | 14,5 | 265 | 132 | 180 | 312 | 10 | 41 | M12 | 89 | 12 | 178 | 212 | 5 | 34 | 216 | 246 |
| 160M | IE3/IE4 | 2-4-6-8 | 42 | 110 | 250 | 350 | 5 | 20 | 605 | 316 | 18,5 | 300 | 160 | 220 | 380 | 12 | 45 | M16 | 108 | 14,5 | 210 | 328 | 15 | 65 | 254 | 293 |
| 160L | IE3/IE4 | 2-4-6-8 | 42 | 110 | 250 | 350 | 5 | 20 | 605 | 316 | 18,5 | 300 | 160 | 220 | 380 | 12 | 45 | M16 | 108 | 14,5 | 254 | 328 | 15 | 65 | 254 | 293 |
| 180M | IE3/IE4 | 2-4-6-8 | 48 | 110 | 250 | 350 | 5 | 14 | 696 | 348 | 18,5 | 300 | 180 | 239 | 419 | 14 | 51,5 | M16 | 121 | 14,5 | 241 | 319 | 15 | 63 | 279 | 316 |
| 180L | IE3/IE4 | 2-4-6-8 | 48 | 110 | 250 | 350 | 5 | 14 | 696 | 348 | 18,5 | 300 | 180 | 239 | 419 | 14 | 51,5 | M16 | 121 | 14,5 | 279 | 319 | 15 | 63 | 279 | 316 |
| 200M | IE3/IE4 | 2-4-6-8 | 55 | 110 | 300 | 400 | 5 | 14 | 737 | 396 | 18,5 | 350 | 200 | 294 | 494 | 16 | 59 | M20 | 133 | 18,5 | 267 | 350 | 20 | 76 | 318 | 372 |
| 200L | IE3/IE4 | 2-4-6-8 | 55 | 110 | 300 | 400 | 5 | 14 | 737 | 396 | 18,5 | 350 | 200 | 294 | 494 | 16 | 59 | M20 | 133 | 18,5 | 305 | 350 | 20 | 76 | 318 | 372 |
| 225S | IE3/IE4 | 2 | 55 | 110 | 350 | 450 | 5 | 20 | 800 | 438 | 18,5 | 400 | 225 | 312 | 537 | 16 | 59 | M20 | 149 | 18,5 | 286 | 360 | 20 | 90 | 356 | 417 |
| | | 830 | | | | | | | | | | | | | | | | | | | | | | | | |
| 225M | IE3/IE4 | 2 | 55 | 110 | 350 | 450 | 5 | 20 | 800 | 438 | 18,5 | 400 | 225 | 312 | 537 | 16 | 59 | M20 | 149 | 18,5 | 311 | 360 | 20 | 90 | 356 | 417 |
| | | 830 | | | | | | | | | | | | | | | | | | | | | | | | |
| 250S | IE3/IE4 | 2 | 60 | 140 | 450 | 550 | 5 | 20 | 896 | 481 | 18,5 | 500 | 250 | 337 | 587 | 18 | 64 | M20 | 168 | 24 | 311 | 433 | 32 | 105 | 406 | 475 |
| | | 65 | | | | | | | | | | | | | | | | | | | | | | | | |
| 250M | IE3/IE4 | 2 | 60 | 140 | 450 | 550 | 5 | 20 | 896 | 481 | 18,5 | 500 | 250 | 337 | 587 | 18 | 64 | M20 | 168 | 24 | 349 | 433 | 32 | 105 | 406 | 475 |
| | | 65 | | | | | | | | | | | | | | | | | | | | | | | | |
| 280S | IE3/IE4 | 2 | 65 | 140 | 450 | 550 | 5 | 20 | 1012 | 547 | 18,5 | 500 | 280 | 402 | 682 | 18 | 69 | M20 | 190 | 24 | 368 | 500 | 35 | 105 | 457 | 531 |
| | | 75 | | | | | | | | | | | | | | | | | | | | | | | | |
| 280M | IE3/IE4 | 2 | 65 | 140 | 450 | 550 | 5 | 20 | 1012 | 547 | 18,5 | 500 | 280 | 402 | 682 | 18 | 69 | M20 | 190 | 24 | 419 | 500 | 35 | 105 | 457 | 531 |
| | | 75 | | | | | | | | | | | | | | | | | | | | | | | | |
| 315S | IE3/IE4 | 2 | 65 | 140 | 550 | 660 | 6 | 25 | 1242 | 622 | 24 | 600 | 315 | 499 | 814 | 18 | 69 | M20 | 216 | 28 | 406 | 636 | 33 | 157 | 508 | 626 |
| | | 1272 | | | | | | | | | | | | | | | | | | | | | | | | |
| 315M | IE3/IE4 | 2 | 65 | 140 | 550 | 660 | 6 | 22 | 1242 | 622 | 24 | 600 | 315 | 499 | 814 | 18 | 69 | M20 | 216 | 28 | 457 | 636 | 33 | 157 | 508 | 626 |
| | | 1272 | | | | | | | | | | | | | | | | | | | | | | | | |
| 315L | IE3/IE4 | 2 | 65 | 140 | 550 | 660 | 6 | 22 | 1389 | 622 | 24 | 600 | 315 | 499 | 814 | 18 | 69 | M20 | 216 | 28 | 508 | 800 | 35 | 145 | 508 | 623 |
| | | 1419 | | | | | | | | | | | | | | | | | | | | | | | | |

[1] Tolerance "j6" up to 28mm, "k6" from 28mm to 48mm, "m6" over 48mm TS EN 50347

[2] Tolerance "j6" up to 250mm, "h6" over 250mm TS EN 50347

[3] Tolerance 063-250 "-0.5mm" / 280-315 "-1mm" TS EN 50347

[4] 7.50kW 2Pole IE3 Compact Motors / 5.50kW 4Pole IE3 Compact Motors

[5] 15.0kW 2Pole IE3 Compact / 11.0kW 4Pole IE3 Compact / 7.50kW 4Pole IE4 Motors

B14 - B34 Construction Types

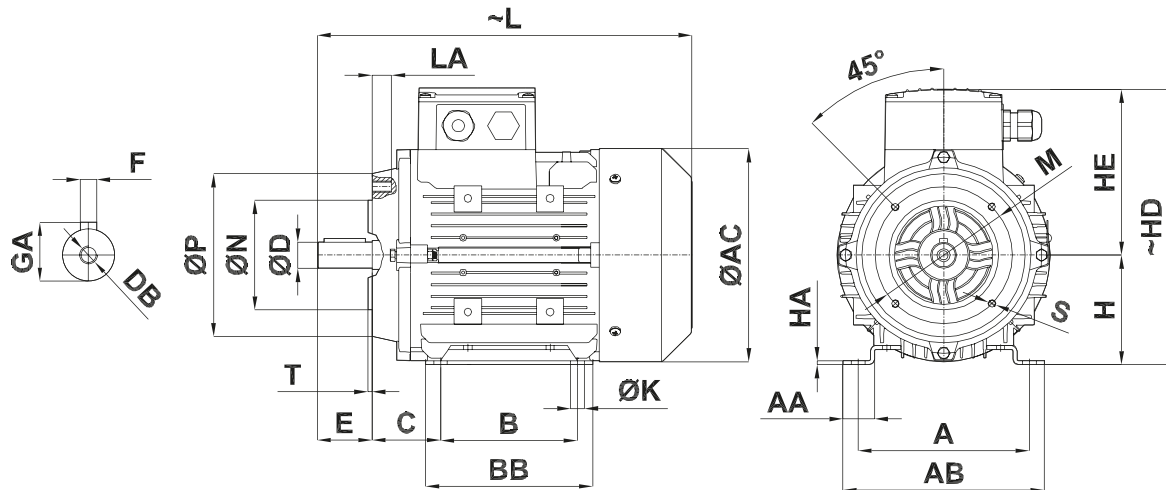

| Frame Size | Efficiency Class | Number of Poles | D ^[1] | N ^[2] | P | E | T | LA | L | AC | S | M | H ^[3] | HE | HD | F | GA | DB | C | ØK | B | BB | HA | AA | A | AB |
|---------------------|------------------|-----------------|------------------|------------------|-----|-----|-----|----|-----|-----|-----|-----|------------------|-----|-----|----|------|-----|-----|------|-----|-----|----|----|-----|-----|
| 063M | IE2/IE3 | 2-4 | 11 | 60 | 90 | 23 | 2,5 | 10 | 213 | 119 | M5 | 75 | 63 | 101 | 164 | 4 | 12,5 | M4 | 40 | 7 | 80 | 104 | 3 | 18 | 100 | 115 |
| 071M | IE2/IE3/IE4 | 2-4-6-8 | 14 | 70 | 105 | 30 | 2,5 | 12 | 242 | 137 | M6 | 85 | 71 | 118 | 189 | 5 | 16 | M5 | 45 | 7 | 90 | 110 | 3 | 19 | 112 | 128 |
| 080M | IE2/IE3/IE4 | 2-4-6-8 | 19 | 80 | 119 | 40 | 3 | 12 | 274 | 155 | M6 | 100 | 80 | 127 | 207 | 6 | 21,5 | M6 | 50 | 10 | 100 | 122 | 3 | 25 | 125 | 148 |
| 090S | IE3/IE4 | 2-4-6-8 | 24 | 95 | 137 | 50 | 3 | 15 | 325 | 176 | M8 | 115 | 90 | 136 | 226 | 8 | 27 | M8 | 56 | 10 | 100 | 151 | 4 | 27 | 140 | 167 |
| 090L | IE3/IE4 | 2-4-6-8 | 24 | 95 | 137 | 50 | 3 | 15 | 325 | 176 | M8 | 115 | 90 | 136 | 226 | 8 | 27 | M8 | 56 | 10 | 125 | 151 | 4 | 27 | 140 | 167 |
| 100L | IE3/IE4 | 2-4-6-8 | 28 | 110 | 160 | 60 | 3,5 | 17 | 369 | 193 | M8 | 130 | 100 | 149 | 249 | 8 | 31 | M10 | 63 | 12 | 140 | 170 | 4 | 31 | 160 | 191 |
| 112M | IE3/IE3C/IE4 | 2-4-6-8 | 28 | 110 | 160 | 60 | 3,5 | 17 | 392 | 215 | M8 | 130 | 112 | 161 | 273 | 8 | 31 | M10 | 70 | 12 | 140 | 177 | 4 | 36 | 190 | 217 |
| 112M ^[4] | IE3C | 2-4 | 28 | 110 | 160 | 60 | 3,5 | 17 | 430 | 215 | M8 | 130 | 112 | 161 | 273 | 8 | 31 | M10 | 70 | 12 | 140 | 177 | 4 | 36 | 190 | 217 |
| 132S | IE3/IE4 | 2-4-6-8 | 38 | 130 | 200 | 80 | 3,5 | 20 | 495 | 257 | M10 | 165 | 132 | 182 | 314 | 10 | 41 | M12 | 89 | 12 | 140 | 212 | 5 | 34 | 216 | 246 |
| 132M | IE3/IE3C/IE4 | 2-4-6-8 | 38 | 130 | 200 | 80 | 3,5 | 20 | 495 | 257 | M10 | 165 | 132 | 182 | 314 | 10 | 41 | M12 | 89 | 12 | 178 | 212 | 5 | 34 | 216 | 246 |
| 132M ^[5] | IE3C/IE4 | 2-4 | 38 | 130 | 200 | 80 | 3,5 | 20 | 543 | 257 | M10 | 165 | 132 | 182 | 314 | 10 | 41 | M12 | 89 | 12 | 178 | 212 | 5 | 34 | 216 | 246 |
| 160M | IE3/IE4 | 2-4-6-8 | 42 | 180 | 250 | 110 | 4 | 23 | 605 | 316 | M12 | 215 | 160 | 226 | 386 | 12 | 45 | M16 | 108 | 14,5 | 210 | 323 | 15 | 65 | 254 | 295 |
| 160L | IE3/IE4 | 2-4-6-8 | 42 | 180 | 250 | 110 | 4 | 23 | 605 | 316 | M12 | 215 | 160 | 226 | 386 | 12 | 45 | M16 | 108 | 14,5 | 254 | 323 | 15 | 65 | 254 | 295 |

[1] Tolerance "j6" up to 28mm, "k6" over 28mm TS EN 50347

[2] Tolerance "j6" TS EN 50347

[3] Tolerance "-0.5mm" TS EN 50347

[4] 7.50kW 2Pole IE3 Compact Motors / 5.50kW 4Pole IE3 Compact Motors

[5] 15.0kW 2Pole IE3 Compact / 11.0kW 4Pole IE3 Compact / 7.50kW 4Pole IE4 Motors

Three-Phase Motor Nameplate Description

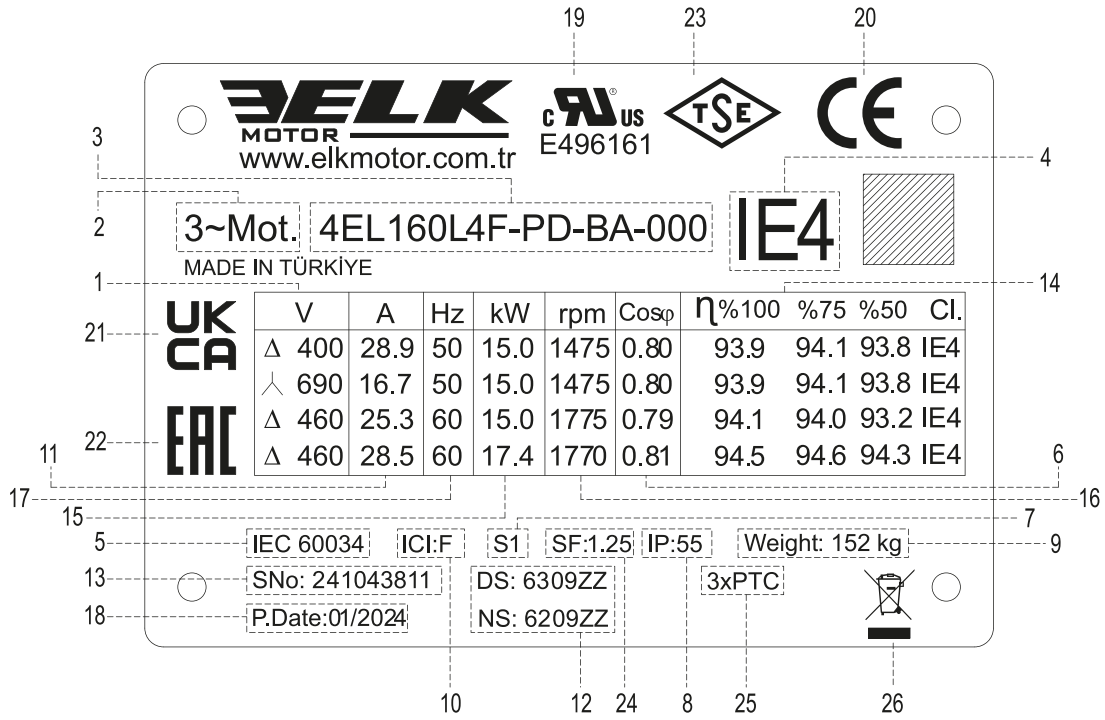

| | | | |
|-----|----------------------------------|-----|------------------|
| 1. | Rated Voltage | 14. | Efficiency |
| 2. | Motor Type: 3 Phase Asynchronous | 15. | Output Power |
| 3. | Motor Code | 16. | Speed |
| 4. | Efficiency Class | 17. | Frequency |
| 5. | Manufacture Standard | 18. | Production Date |
| 6. | Power Factor | 19. | UL Logo |
| 7. | Duty Cycle | 20. | CE Mark |
| 8. | Protection Class | 21. | UKCA Mark |
| 9. | Motor Weight | 22. | EAC Logo |
| 10. | Insulation Class | 23. | TSE Logo |
| 11. | Rated Current | 24. | Service Factor |
| 12. | Bearing Type | 25. | 3xPTC Thermistor |
| 13. | Serial Number | 26. | WEEE Symbol |



The nameplate shows the identification, and the most important technical data. The nameplate also defines the limits of proper usage, and manufacturing year of the motors. The first two digits in the serial number, shows the manufacturing year. For example, 24XXXXXXXX shows that the product is manufactured in 2024.

Three-Phase Motors Spare Parts

All standard three-phase motors manufactured by ELK MOTOR consist of the following main components:

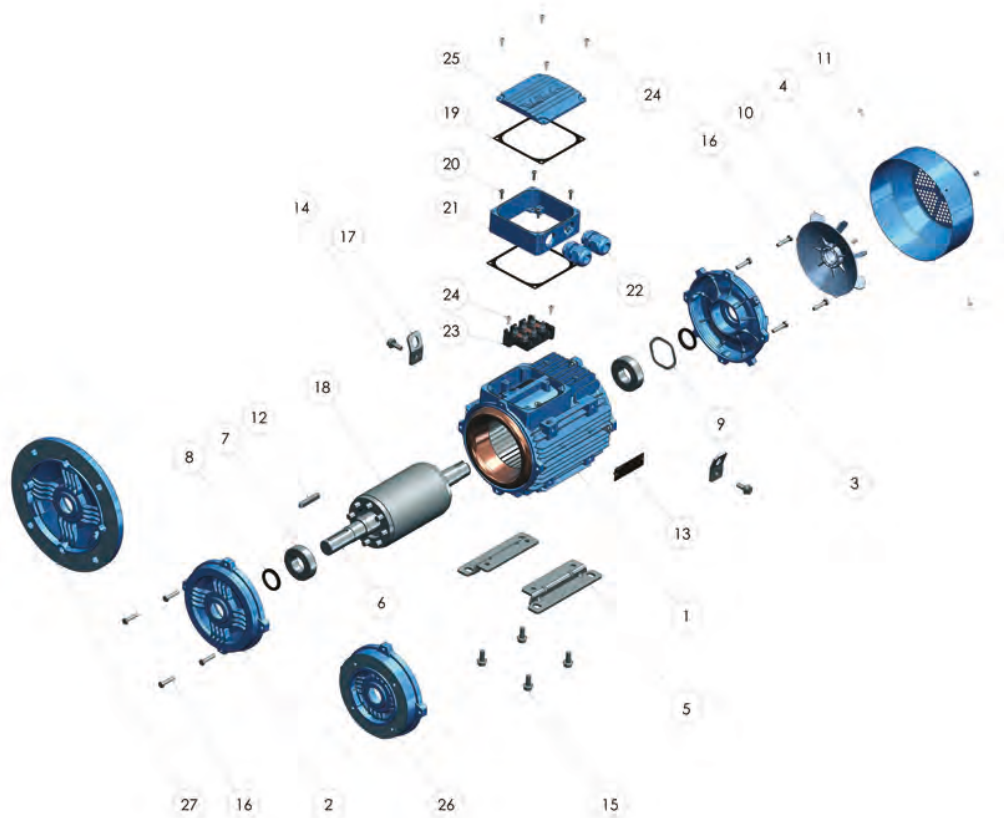

- | | |
|---------------------|-------------------------|
| 1. Housing | 15. Screw |
| 2. End Shield (DE) | 16. Bolt |
| 3. End Shield (NDE) | 17. Lifting Lug |
| 4. Fan Cover | 18. Squirrel Cage Rotor |
| 5. Mounting Foot | 19. Terminal Box Gasket |
| 6. Shaft | 20. Screw |
| 7. Bearing | 21. Terminal Box |
| 8. Shaft Sealing | 22. Cable Gland |
| 9. Spring Washer | 23. Terminal |
| 10. Fan | 24. Screw |
| 11. Screw | 25. Terminal Box Cover |
| 12. Key | 26. Flange B14 |
| 13. Nameplate | 27. Flange B5 |
| 14. Screw | |

While ordering spare parts, the motor serial number, full type designation and product code, as stated on the nameplate, must be specified. For field service, spare parts and additional information, please contact us.

SINGLE-PHASE MOTORS



Technical
Information

Electrical Construction

Electrical Construction

Our single phase standard motors have an F class (155°C) electrical insulation system. However, all standard motors in our product range operate within B class temperature rise limits. This ensures that the provided temperature class has a safety margin, allowing our motors to operate under more demanding conditions than specified or to have a longer service life under normal conditions.

Motors with H class insulation can be manufactured according to customer requirements.

Electrical Connections

| Cable Gland and Blind Cap | | | | | Terminal Connections | | | | |
|---------------------------|---------|---------|-----|-----|----------------------|-----|-----|-----|-----|
| Frame Size | 063 | 071 | 080 | 090 | Frame Size | 063 | 071 | 080 | 090 |
| Cable Glands | M16x1,5 | M20x1,5 | | | Terminal Size | M4 | | | |

Our single-phase motors are manufactured with a standard voltage of 230V 50Hz and are wired to rotate clockwise when viewed from the drive end. For counterclockwise rotation, the terminal connections should be configured as specified below.

| Terminal Marking Information | |
|------------------------------|-----------------------------|
| U1 , U2 | Main Winding Terminals |
| Z1 , Z2 | Auxiliary Winding Terminals |
| Cr , Cs | Capacitor Terminals |

Terminal Connections for Single-Phase Run Capacitor Motors

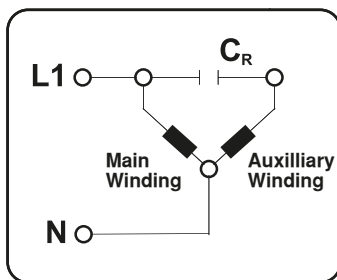

Circuit Connection

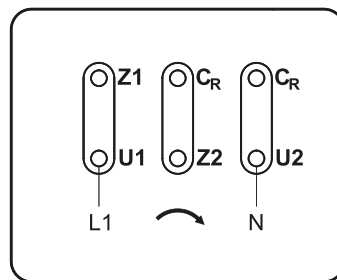

Clockwise Rotation

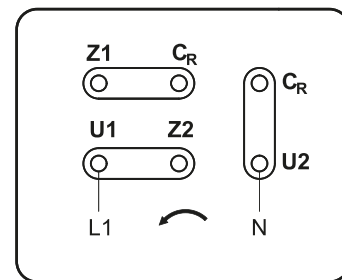

Counter-Clockwise Rotation

Terminal Connections for Single-Phase Run and Start Capacitor Motors

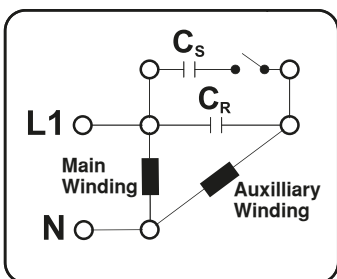

Circuit Connection

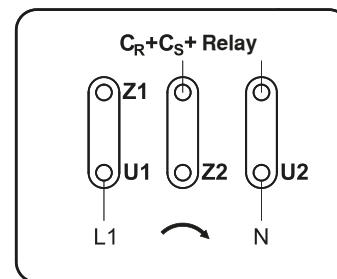

Clockwise Rotation

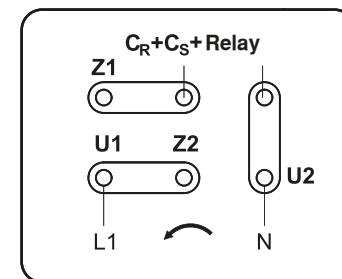

Counter-Clockwise Rotation

Mechanical Structure

Single-phase ELK motors are equipped with a removable foot structure for the corresponding frame sizes. Due to the dimensions of the terminal box, the feet can only be mounted on the underside of the frame. Additionally, the symmetrical frame and foot design of single-phase ELK motors ensure that the C dimension remains constant when the shaft-side cover, rear cover, and shaft direction are altered. This design allows for the terminal box to be positioned either near the shaft side or the fan side.

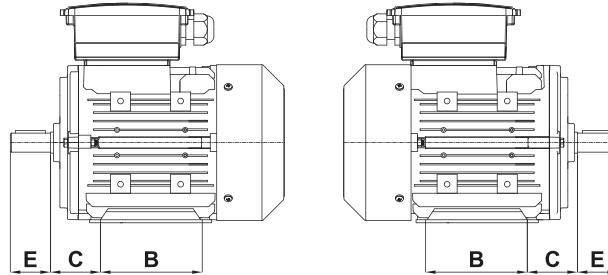

The materials used in our products are specified below.

| Frame Size | Housing | End Shield DE | End Shield NDE | Terminal Box & Cover | Feet | Fan Cover | Fan |
|------------|----------|---------------|----------------|----------------------|-------------|-------------|---------|
| 63 | Aluminum | Aluminum | Aluminum | Aluminum | Steel Sheet | Steel Sheet | Plastic |
| 71 | Aluminum | Aluminum | Aluminum | Aluminum | Steel Sheet | Steel Sheet | Plastic |
| 80 | Aluminum | Aluminum | Aluminum | Aluminum | Steel Sheet | Steel Sheet | Plastic |
| 90 | Aluminum | Aluminum | Aluminum | Aluminum | Steel Sheet | Steel Sheet | Plastic |

Bearings

Single-phase ELK motors utilize deep groove ball bearings as specified in the table.

| Frame Size | Number of Poles | Drive End Bearing | Non Drive end Bearing |
|------------|-----------------|-------------------|-----------------------|
| 63 | 2-4 | 6201 ZZ C3 | 6201 ZZ C3 |
| 71 | 2-4 | 6202 ZZ C3 | 6202 ZZ C3 |
| 80 | 2-4 | 6204 ZZ C3 | 6204 ZZ C3 |
| 90 | 2-4 | 6205 ZZ C3 | 6205 ZZ C3 |

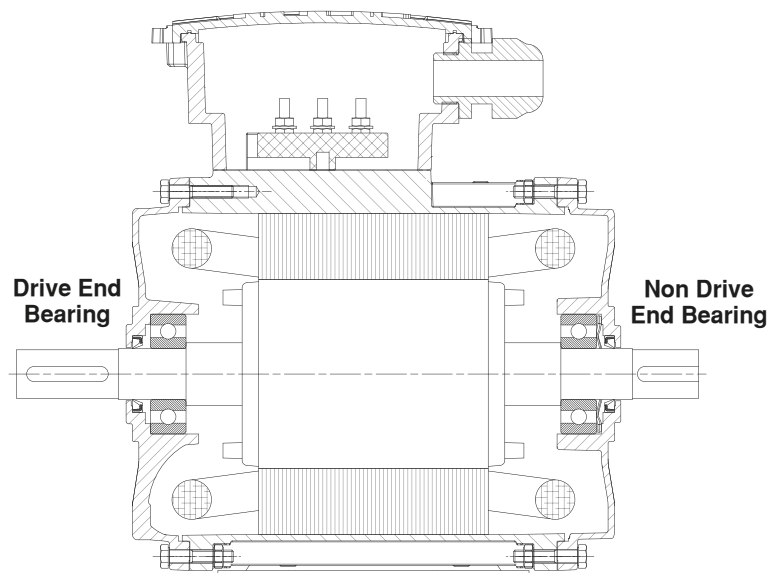

Radial Loads

HORIZONTAL MOUNTING - Permissible Axial Loads
 Mounting Positions IM: B3, B5, B6, B7, B8, B14, B34, B35

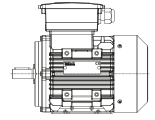

| Frame Size | Fa = 0 | |
|-----------------------------|------------------------|---|
| | Fr ₀ | Fr _{max} |
| 2 Poles 3000 rpm | Fr ₀ [N] | Fr _{max} [N] ^{max} |
| 63 | 350 | 300 |
| 71 | 380 | 340 |
| 80 | 640 | 550 |
| 90 | 750 | 660 |
| 4 Poles 1500 rpm | Fr ₀ [N] | Fr _{max} [N] ^{max} |
| 63 | 430 | 390 |
| 71 | 520 | 440 |
| 80 | 800 | 700 |
| 90 | 950 | 780 |

Axial Loads

HORIZONTAL MOUNTING - Permissible Axial Loads
 Mounting Positions IM: B3, B5, B6, B7, B8, B14, B34, B35

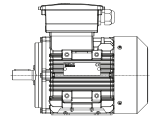

| Frame Size | Push | | | Pull |
|-----------------------------|------------------------|---------------------------------------|---|------------------------|
| | Fr = 0 | Fr = Fr ₀ | Fr = Fr _{max} | Fr = 0 |
| | Fa ₀ | Fa ₀ , Fr ₀ | Fa ₀ , Fr _{max} | Fa ₀ |
| 2 Poles 3000 rpm | Fa ₀ [N] | Fa ₀ [N] | Fa ₀ [N] | Fa ₀ [N] |
| 63 | 90 | 90 | 90 | 220 |
| 71 | 110 | 110 | 110 | 250 |
| 80 | 190 | 190 | 190 | 395 |
| 90 | 210 | 210 | 210 | 400 |
| 4 Poles 1500 rpm | Fa ₀ [N] | Fa ₀ [N] | Fa ₀ [N] | Fa ₀ [N] |
| 63 | 90 | 90 | 90 | 330 |
| 71 | 110 | 110 | 110 | 360 |
| 80 | 190 | 190 | 190 | 560 |
| 90 | 210 | 210 | 210 | 585 |

Fa₀ : Permissible maximum axial load

Fr : Radial force acting on the shaft

Fr₀ : Permissible maximum radial load at the end of the shaft

Fr_{max} : Permissible maximum radial load at the shaft end

Permissible load calculations are based on a bearing life of L_{h10} 20,000 hours according to ISO 281.

Axial Loads

VERTICAL MOUNTING - Shaft Up - Permissible Axial Loads
Mounting Positions IM: V3, V6, V19, V35, V37

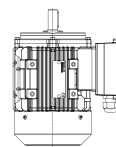

| Frame Size | Push | | | Pull |
|-----------------------------|-------------------------------|-------------------------------|-------------------------------|-------------------------------|
| | Fr = 0 | Fr = Fr ₀ | Fr = Fr _{max} | Fr = 0 |
| | | | | |
| 2 Poles 3000 rpm | Fa₀ [N] | Fa₀ [N] | Fa₀ [N] | Fa₀ [N] |
| 63 | 90 | 90 | 90 | 230 |
| 71 | 100 | 100 | 100 | 265 |
| 80 | 170 | 170 | 170 | 425 |
| 90 | 180 | 180 | 180 | 450 |
| 4 Poles 1500 rpm | Fa₀ [N] | Fa₀ [N] | Fa₀ [N] | Fa₀ [N] |
| 63 | 90 | 90 | 90 | 345 |
| 71 | 95 | 95 | 95 | 380 |
| 80 | 160 | 160 | 160 | 600 |
| 90 | 170 | 170 | 170 | 650 |

Axial Loads

VERTICAL MOUNTING - Shaft Down - Permissible Axial Loads
Mounting Positions IM: V1, V5, V15, V17, V18

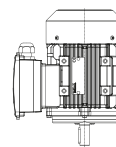

| Frame Size | Push | | | Pull |
|-----------------------------|-------------------------------|-------------------------------|-------------------------------|-------------------------------|
| | Fr = 0 | Fr = Fr ₀ | Fr = Fr _{max} | Fr = 0 |
| | | | | |
| 2 Poles 3000 rpm | Fa₀ [N] | Fa₀ [N] | Fa₀ [N] | Fa₀ [N] |
| 63 | 110 | 110 | 110 | 210 |
| 71 | 130 | 130 | 130 | 235 |
| 80 | 220 | 220 | 220 | 385 |
| 90 | 250 | 250 | 250 | 375 |
| 4 Poles 1500 rpm | Fa₀ [N] | Fa₀ [N] | Fa₀ [N] | Fa₀ [N] |
| 63 | 120 | 110 | 120 | 300 |
| 71 | 130 | 130 | 130 | 340 |
| 80 | 220 | 220 | 220 | 540 |
| 90 | 260 | 260 | 260 | 545 |

Fa₀ : Permissible maximum axial load

Fr : Radial force acting on the shaft

Fr₀ : Permissible maximum radial load at the end of the shaft

Fr_{max} : Permissible maximum radial load at the shaft end

Permissible load calculations are based on a bearing life of L_{h10} 20,000 hours according to ISO 281.

Product Type Codes of Single-Phase Motors

2 **MD** **071** **M** **4** **C** **PD** **M8** **000**

| | | |
|-----|--------|---|
| 2 | -----> | Motor Efficiency Class 2: IE2 |
| MD | -----> | Basic Motor Types MD : Single-Phase Motors with Start Capacitor MS : Single-Phase Motors with Start and Run Capacitor |
| 071 | -----> | Frame Size: 63, 71, 80, 90 Height of the shaft axis from feet base of motor(mm) |
| M | -----> | Housing Length S : Short M: Medium L : Long |
| 4 | -----> | Number of Poles 2: 2 Poles 3000 rpm 4: 4 Poles 1500 rpm |
| C | -----> | Core Length: A, B, C, D, E |
| PD | -----> | Construction Types/Flange Types PD: B3 Foot Mounted FA: B5 Flange FB: B14/2 Flange PB: B14/2 Feet FC : B14 Flange FS : Special Flange PA : B35 PC : B34 PS :Foot mounted with special flange Y0..Y9 :With flange for gearbox connection PX : Foot mounted without drive end shield XX : Without foot and drive end shield Z0-Z9 : Foot mounted Yılmaz type |
| M8 | -----> | Electrical Specifications AA..ZZ Voltage, Frequency and Electrical features M8 : 230V 50Hz 70 : 220V 50Hz Y0: 220V 60Hz Y2: 230V 60Hz |
| 000 | -----> | Additional Motor Features 000 : Standard Motor |

SINGLE-PHASE MOTORS



E/E IE2 Motors



Electrical Characteristics

230V 50Hz 3000 rpm with Run Capacitor

Duty Cycle : S1 (Continuous Operation)

Insulation Class : F (155°C)

Temperature Rise : B (80°K)

IE2

| Voltage (V) | Type | Rated Values | | | | | | | | Starting Values | | Break Down Torque | Run Capacitor Capacity | Moment of Inertia | B3 Motor Weight |
|--------------|-----------|--------------|-------|---------|--------|--------------|---------------------|------|------|--------------------------------|--------------------------------|-------------------|------------------------|-------------------|-----------------|
| | | Power | Speed | Current | Torque | Power Factor | Efficiency % η | | | Current | Torque | | | | |
| | | kW | rpm | A | Nm | Cos ϕ | 4/4 | 3/4 | 1/2 | I _A /I _N | M _A /M _N | | | | |
| 1~ 230V 50Hz | 2MD063M2A | 0,18 | 2785 | 1,25 | 0,62 | 0,98 | 64,0 | 61,0 | 55,2 | 3,00 | 0,60 | 1,90 | 10 | 0,00013 | 4,10 |
| | 2MD063M2B | 0,25 | 2820 | 1,68 | 0,85 | 0,97 | 67,0 | 63,1 | 57,1 | 3,30 | 0,65 | 2,00 | 15 | 0,00016 | 4,30 |
| | 2MD071M2B | 0,37 | 2840 | 2,20 | 1,24 | 0,98 | 74,4 | 73,0 | 64,5 | 3,70 | 0,60 | 1,90 | 20 | 0,00032 | 6,60 |
| | 2MD071M2C | 0,55 | 2845 | 3,18 | 1,85 | 0,98 | 76,5 | 75,2 | 68,0 | 3,80 | 0,60 | 2,00 | 25 | 0,00039 | 7,60 |
| | 2MD080M2B | 0,75 | 2800 | 4,31 | 2,56 | 0,98 | 77,4 | 74,4 | 67,3 | 3,80 | 0,60 | 2,10 | 30 | 0,00094 | 9,90 |
| | 2MD080M2C | 1,10 | 2810 | 6,05 | 3,74 | 0,99 | 79,6 | 78,6 | 73,0 | 3,80 | 0,57 | 2,10 | 40 | 0,00108 | 11,6 |
| | 2MD090S2B | 1,50 | 2810 | 8,20 | 5,10 | 0,98 | 81,3 | 81,2 | 76,0 | 4,00 | 0,52 | 2,00 | 60 | 0,00160 | 16,2 |
| | 2MD090L2D | 2,20 | 2850 | 11,8 | 7,37 | 0,98 | 83,2 | 82,0 | 75,7 | 4,40 | 0,52 | 2,10 | 80 | 0,00234 | 19,0 |

230V 50Hz 1500 rpm with Run Capacitor

Duty Cycle : S1 (Continuous Operation)

Insulation Class : F (155°C)

Temperature Rise : B (80°K)

IE2

| Voltage (V) | Type | Rated Values | | | | | | | | Starting Values | | Break Down Torque | Run Capacitor Capacity | Moment of Inertia | B3 Motor Weight |
|--------------|-----------|--------------|-------|---------|--------|--------------|---------------------|------|------|--------------------------------|--------------------------------|-------------------|------------------------|-------------------|-----------------|
| | | Power | Speed | Current | Torque | Power Factor | Efficiency % η | | | Current | Torque | | | | |
| | | kW | rpm | A | Nm | Cos ϕ | 4/4 | 3/4 | 1/2 | I _A /I _N | M _A /M _N | | | | |
| 1~ 230V 50Hz | 2MD063M4B | 0,12 | 1415 | 0,91 | 0,81 | 0,97 | 59,1 | 50,8 | 40,5 | 2,30 | 0,58 | 1,75 | 10 | 0,00019 | 4,40 |
| | 2MD063M4C | 0,18 | 1420 | 1,27 | 1,21 | 0,95 | 64,7 | 57,2 | 44,0 | 2,50 | 0,60 | 1,90 | 15 | 0,00023 | 5,00 |
| | 2MD071M4C | 0,25 | 1445 | 1,73 | 1,65 | 0,93 | 68,5 | 61,4 | 49,8 | 3,50 | 0,60 | 2,00 | 15 | 0,00071 | 7,40 |
| | 2MD071M4D | 0,37 | 1440 | 2,36 | 2,45 | 0,94 | 72,7 | 65,8 | 54,3 | 3,20 | 0,50 | 2,00 | 20 | 0,00086 | 8,20 |
| | 2MD080M4C | 0,55 | 1415 | 3,20 | 3,71 | 0,97 | 77,1 | 72,0 | 63,1 | 3,50 | 0,55 | 2,00 | 30 | 0,00184 | 10,6 |
| | 2MD080M4D | 0,75 | 1400 | 4,18 | 5,12 | 0,98 | 79,6 | 77,2 | 69,5 | 3,50 | 0,55 | 1,90 | 30 | 0,00210 | 12,4 |
| | 2MD090S4D | 1,10 | 1420 | 6,00 | 7,40 | 0,98 | 81,4 | 79,2 | 71,8 | 4,00 | 0,45 | 1,90 | 40 | 0,00295 | 18,1 |
| | 2MD090L4E | 1,50 | 1420 | 8,20 | 10,1 | 0,96 | 82,8 | 81,0 | 74,2 | 4,00 | 0,45 | 1,70 | 60 | 0,00373 | 18,7 |



Electrical Characteristics

Duty Cycle : S1 (Continuous Operation)
 Insulation Class : F (155°C)
 Temperature Rise : B (80°K)

IE2

230V 50Hz 3000 rpm with Run and Start Capacitors

| Voltage (V) | Type | Rated Values | | | | | | | | | Starting Values | | Break Down Torque | Capacitor | | Moment of Inertia | B3 Motor Weight |
|--------------|-----------|--------------|-------|---------|--------|--------------|---------------------|------|------|--------------------------------|--------------------------------|--------------------------------|-------------------|-----------|------------------|-------------------|-----------------|
| | | Power | Speed | Current | Torque | Power Factor | Efficiency % η | | | Current | Torque | Run | | Start | | | |
| | | kW | rpm | A | Nm | Cos ϕ | 4/4 | 3/4 | 1/2 | I _A /I _N | M _A /M _N | M _K /M _N | μ F | μ F | kgm ² | kg | |
| 1~ 230V 50Hz | 2MS063M2A | 0,18 | 2785 | 1,25 | 0,62 | 0,98 | 64,0 | 61,0 | 55,2 | 4,80 | 2,70 | 1,90 | 10 | 36-43 | 0,00013 | 4,30 | |
| | 2MS063M2B | 0,25 | 2820 | 1,68 | 0,85 | 0,97 | 67,0 | 63,1 | 57,1 | 4,90 | 2,80 | 2,00 | 15 | 43-52 | 0,00016 | 4,50 | |
| | 2MS071M2B | 0,37 | 2840 | 2,20 | 1,24 | 0,98 | 74,4 | 73,0 | 64,5 | 4,90 | 2,60 | 1,90 | 20 | 53-64 | 0,00032 | 6,80 | |
| | 2MS071M2C | 0,55 | 2845 | 3,18 | 1,85 | 0,98 | 76,5 | 75,2 | 68,0 | 4,90 | 2,60 | 2,00 | 25 | 72-86 | 0,00039 | 7,80 | |
| | 2MS080M2B | 0,75 | 2800 | 4,31 | 2,56 | 0,98 | 77,4 | 74,4 | 67,3 | 5,30 | 2,60 | 2,10 | 30 | 88-106 | 0,00094 | 10,1 | |
| | 2MS080M2C | 1,10 | 2810 | 6,05 | 3,74 | 0,99 | 79,6 | 78,6 | 73,0 | 5,30 | 2,70 | 2,10 | 40 | 145-174 | 0,00108 | 11,8 | |
| | 2MS090S2B | 1,50 | 2810 | 8,20 | 5,10 | 0,98 | 81,3 | 81,2 | 76,0 | 5,00 | 2,20 | 2,00 | 60 | 189-227 | 0,00160 | 16,4 | |
| | 2MS090L2D | 2,20 | 2850 | 11,8 | 7,37 | 0,98 | 83,2 | 82,0 | 75,7 | 4,80 | 1,50 | 2,10 | 80 | 189-227 | 0,00234 | 19,2 | |

Duty Cycle : S1 (Continuous Operation)
 Insulation Class : F (155°C)
 Temperature Rise : B (80°K)

IE2

230V 50Hz 1500 rpm with Run and Start Capacitors

| Voltage (V) | Type | Rated Values | | | | | | | | | Starting Values | | Break Down Torque | Capacitor | | Moment of Inertia | B3 Motor Weight |
|--------------|-----------|--------------|-------|---------|--------|--------------|---------------------|------|------|--------------------------------|--------------------------------|--------------------------------|-------------------|-----------|------------------|-------------------|-----------------|
| | | Power | Speed | Current | Torque | Power Factor | Efficiency % η | | | Current | Torque | Run | | Start | | | |
| | | kW | rpm | A | Nm | Cos ϕ | 4/4 | 3/4 | 1/2 | I _A /I _N | M _A /M _N | M _K /M _N | μ F | μ F | kgm ² | kg | |
| 1~ 230V 50Hz | 2MS063M4B | 0,12 | 1415 | 0,91 | 0,81 | 0,97 | 59,1 | 50,8 | 40,5 | 4,90 | 2,60 | 1,75 | 10 | 30-36 | 0,00019 | 4,60 | |
| | 2MS063M4C | 0,18 | 1420 | 1,27 | 1,21 | 0,95 | 64,7 | 57,2 | 44,0 | 4,80 | 2,70 | 1,90 | 15 | 30-36 | 0,00023 | 5,20 | |
| | 2MS071M4C | 0,25 | 1445 | 1,73 | 1,65 | 0,93 | 68,5 | 61,4 | 49,8 | 4,90 | 2,70 | 2,00 | 15 | 36-43 | 0,00071 | 7,60 | |
| | 2MS071M4D | 0,37 | 1440 | 2,36 | 2,45 | 0,94 | 72,7 | 65,8 | 54,3 | 4,70 | 2,50 | 2,00 | 20 | 53-64 | 0,00086 | 8,40 | |
| | 2MS080M4C | 0,55 | 1415 | 3,20 | 3,71 | 0,97 | 77,1 | 72,0 | 63,1 | 4,60 | 2,60 | 2,00 | 30 | 64-77 | 0,00184 | 10,8 | |
| | 2MS080M4D | 0,75 | 1400 | 4,18 | 5,12 | 0,98 | 79,6 | 77,2 | 69,5 | 4,50 | 2,60 | 1,90 | 30 | 72-86 | 0,00210 | 12,6 | |
| | 2MS090S4D | 1,10 | 1420 | 6,00 | 7,40 | 0,98 | 81,4 | 79,2 | 71,8 | 5,10 | 2,60 | 1,90 | 40 | 145-174 | 0,00295 | 18,3 | |
| | 2MS090L4E | 1,50 | 1420 | 8,20 | 10,1 | 0,96 | 82,8 | 81,0 | 74,2 | 4,50 | 2,10 | 1,70 | 60 | 161-193 | 0,00373 | 18,9 | |



SINGLE-PHASE MOTORS



Dimensions

Motors with Run Capacitor

B3 Construction Type

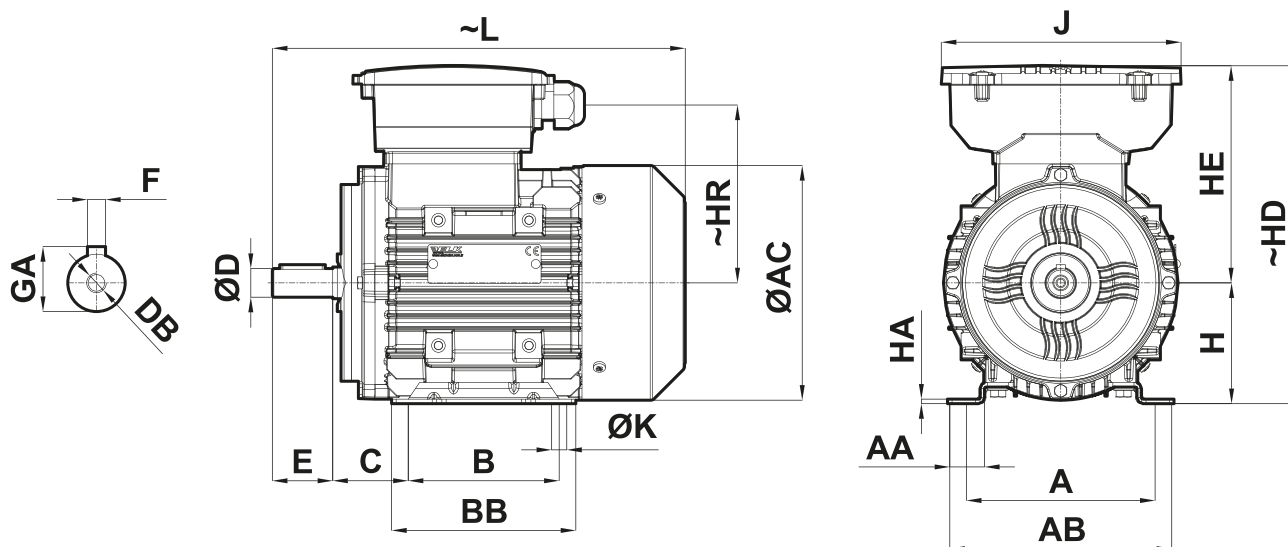

| Frame Size | Number of Poles | D ^[1] | E | L | AC | HR | H ^[2] | HE | HD | F | GA | DB | C | $\varnothing K$ | B | BB | HA | AA | A | AB | J |
|------------|-----------------|------------------|----|-----|-----|-----|------------------|-----|-----|---|------|----|----|-----------------|-----|-----|----|----|-----|-----|-----|
| 063M | 2-4 | 11 | 23 | 213 | 119 | 92 | 63 | 118 | 181 | 4 | 12,5 | M4 | 40 | 7 | 80 | 104 | 3 | 18 | 100 | 115 | 153 |
| 071M | 2-4 | 14 | 30 | 242 | 137 | 108 | 71 | 135 | 206 | 5 | 16 | M5 | 45 | 7 | 90 | 110 | 3 | 19 | 112 | 128 | 159 |
| 080M | 2-4 | 19 | 40 | 274 | 155 | 117 | 80 | 144 | 224 | 6 | 21,5 | M6 | 50 | 10 | 100 | 122 | 3 | 25 | 125 | 148 | 159 |
| 090S | 2-4 | 24 | 50 | 325 | 176 | 133 | 90 | 170 | 260 | 8 | 27 | M8 | 56 | 10 | 125 | 151 | 4 | 27 | 140 | 167 | 173 |
| 090L | 2-4 | 24 | 50 | 325 | 176 | 133 | 90 | 170 | 260 | 8 | 27 | M8 | 56 | 10 | 125 | 151 | 4 | 27 | 140 | 167 | 173 |

[1] Tolerance "j6" TS EN 50347

[2] Tolerance "-0.5mm" TS EN 50347

Motors with Run Capacitor

B14 - B34 Construction Types

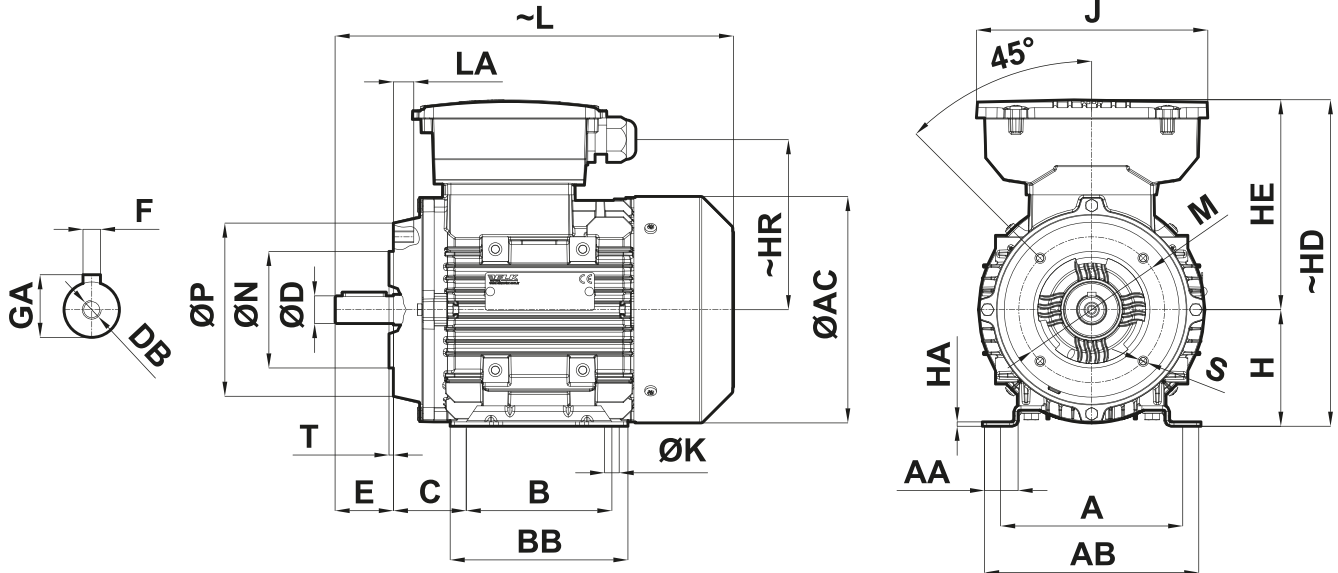

| Frame Size | Number of Poles | D ^[1] | N ^[2] | P | E | T | LA | L | AC | S | M | HR | H ^[3] | HE | HD | F | GA | DB | C | ØK | B | BB | HA | AA | A | AB | J |
|------------|-----------------|------------------|------------------|-----|----|-----|----|-----|-----|----|-----|-----|------------------|-----|-----|---|------|----|----|----|-----|-----|----|----|-----|-----|-----|
| 063M | 2-4 | 11 | 60 | 90 | 23 | 2,5 | 10 | 213 | 119 | M5 | 75 | 92 | 63 | 118 | 181 | 4 | 12,5 | M4 | 40 | 7 | 80 | 104 | 3 | 18 | 100 | 115 | 153 |
| 071M | 2-4 | 14 | 70 | 105 | 30 | 2,5 | 12 | 242 | 137 | M6 | 85 | 108 | 71 | 135 | 206 | 5 | 16 | M5 | 45 | 7 | 90 | 110 | 3 | 19 | 112 | 128 | 159 |
| 080M | 2-4 | 19 | 80 | 119 | 40 | 3 | 12 | 274 | 155 | M6 | 100 | 117 | 80 | 144 | 224 | 6 | 21,5 | M6 | 50 | 10 | 100 | 122 | 3 | 25 | 125 | 148 | 159 |
| 090S | 2-4 | 24 | 95 | 137 | 50 | 3 | 15 | 325 | 176 | M8 | 115 | 133 | 90 | 170 | 260 | 8 | 27 | M8 | 56 | 10 | 125 | 151 | 4 | 27 | 140 | 167 | 173 |
| 090L | 2-4 | 24 | 95 | 137 | 50 | 3 | 15 | 325 | 176 | M8 | 115 | 133 | 90 | 170 | 260 | 8 | 27 | M8 | 56 | 10 | 125 | 151 | 4 | 27 | 140 | 167 | 173 |

[1] Tolerance "j6" TS EN 50347

[2] Tolerance "j6" TS EN 50347

[3] Tolerance "-0.5mm" TS EN 50347

Motors with Run Capacitor

B5 – B35 Construction Types

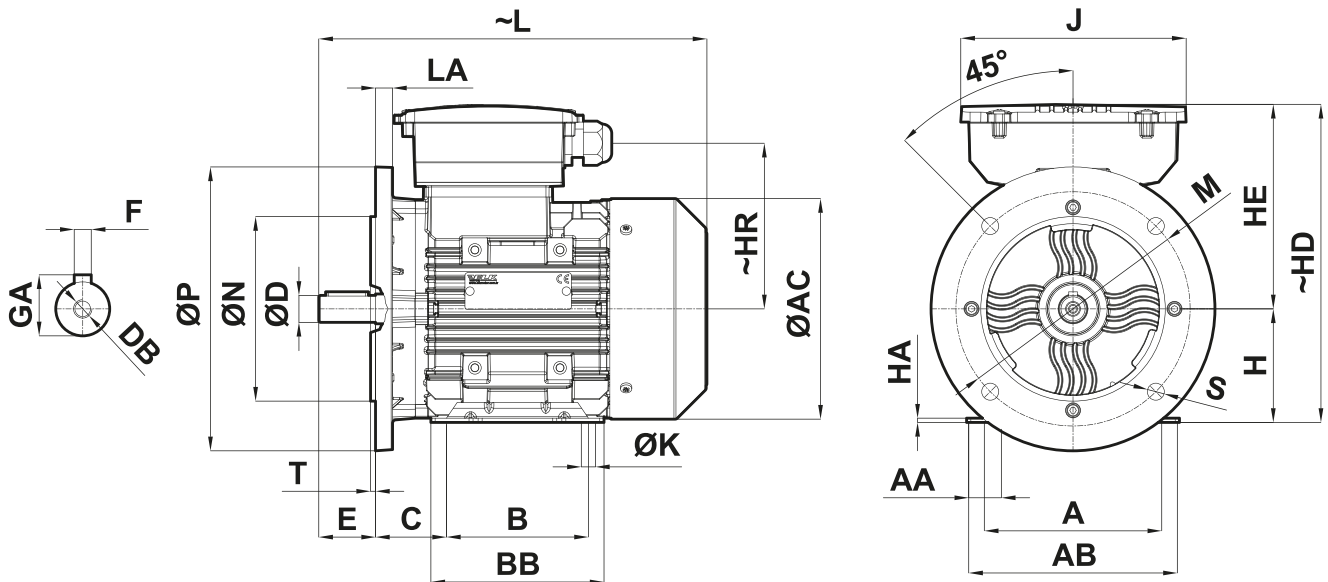

| Frame Size | Number of Poles | D ^[1] | E | N ^[2] | P | T | LA | L | AC | S | M | HR | H ^[3] | HE | HD | F | GA | DB | C | ØK | B | BB | HA | AA | A | AB | J |
|------------|-----------------|------------------|----|------------------|-----|-----|----|-----|-----|----|-----|-----|------------------|-----|-----|---|------|----|----|----|-----|-----|----|----|-----|-----|-----|
| 063M | 2-4 | 11 | 23 | 95 | 140 | 3,0 | 8 | 213 | 119 | 10 | 115 | 92 | 63 | 118 | 181 | 4 | 12,5 | M4 | 40 | 7 | 80 | 104 | 3 | 18 | 100 | 115 | 153 |
| 071M | 2-4 | 14 | 30 | 110 | 160 | 3,5 | 8 | 242 | 137 | 10 | 130 | 108 | 71 | 135 | 206 | 5 | 16 | M5 | 45 | 7 | 90 | 110 | 3 | 19 | 112 | 128 | 159 |
| 080M | 2-4 | 19 | 40 | 130 | 200 | 3,5 | 12 | 274 | 155 | 12 | 165 | 117 | 80 | 144 | 224 | 6 | 21,5 | M6 | 50 | 10 | 100 | 122 | 3 | 25 | 125 | 148 | 159 |
| 090S | 2-4 | 24 | 50 | 130 | 200 | 3,5 | 12 | 325 | 176 | 12 | 165 | 133 | 90 | 170 | 260 | 8 | 27 | M8 | 56 | 10 | 125 | 151 | 4 | 27 | 140 | 167 | 173 |
| 090L | 2-4 | 24 | 50 | 130 | 200 | 3,5 | 12 | 325 | 176 | 12 | 165 | 133 | 90 | 170 | 260 | 8 | 27 | M8 | 56 | 10 | 125 | 151 | 4 | 27 | 140 | 167 | 173 |

[1] Tolerance "j6" TS EN 50347

[2] Tolerance "j6" TS EN 50347

[3] Tolerance "-0.5mm" TS EN 50347

Motors with Run and Start Capacitors

B3 Construction Type

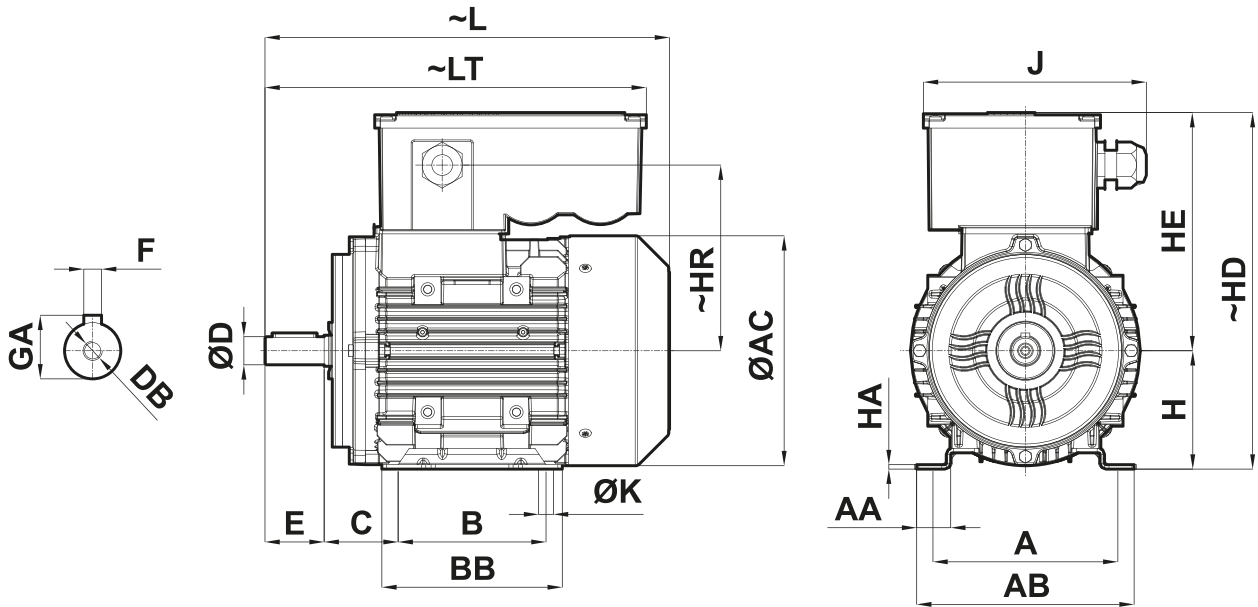

| Frame Size | Number of Poles | D ^[1] | E | L | LT | AC | HR | H ^[2] | HE | HD | F | GA | DB | C | $\varnothing K$ | B | BB | HA | AA | A | AB | J |
|------------|-----------------|------------------|----|-----|-----|-----|-----|------------------|-----|-----|---|------|----|----|-----------------|-----|-----|----|----|-----|-----|-----|
| 063M | 2-4 | 11 | 23 | 213 | 208 | 119 | 94 | 63 | 160 | 223 | 4 | 12,5 | M4 | 40 | 7 | 80 | 104 | 3 | 18 | 100 | 115 | 128 |
| 071M | 2-4 | 14 | 30 | 242 | 258 | 137 | 117 | 71 | 159 | 230 | 5 | 16 | M5 | 45 | 7 | 90 | 110 | 3 | 19 | 112 | 128 | 169 |
| 080M | 2-4 | 19 | 40 | 274 | 271 | 155 | 126 | 80 | 168 | 248 | 6 | 21,5 | M6 | 50 | 10 | 100 | 122 | 3 | 25 | 125 | 148 | 169 |
| 090S | 2-4 | 24 | 50 | 325 | 304 | 176 | 135 | 90 | 177 | 267 | 8 | 27 | M8 | 56 | 10 | 125 | 151 | 4 | 27 | 140 | 167 | 158 |
| 090L | 2-4 | 24 | 50 | 325 | 304 | 176 | 135 | 90 | 177 | 267 | 8 | 27 | M8 | 56 | 10 | 125 | 151 | 4 | 27 | 140 | 167 | 158 |

[1] Tolerance "j6" TS EN 50347

[2] Tolerance "-0.5mm" TS EN 50347

Motors with Run and Start Capacitors

B14 – B34 Construction Types

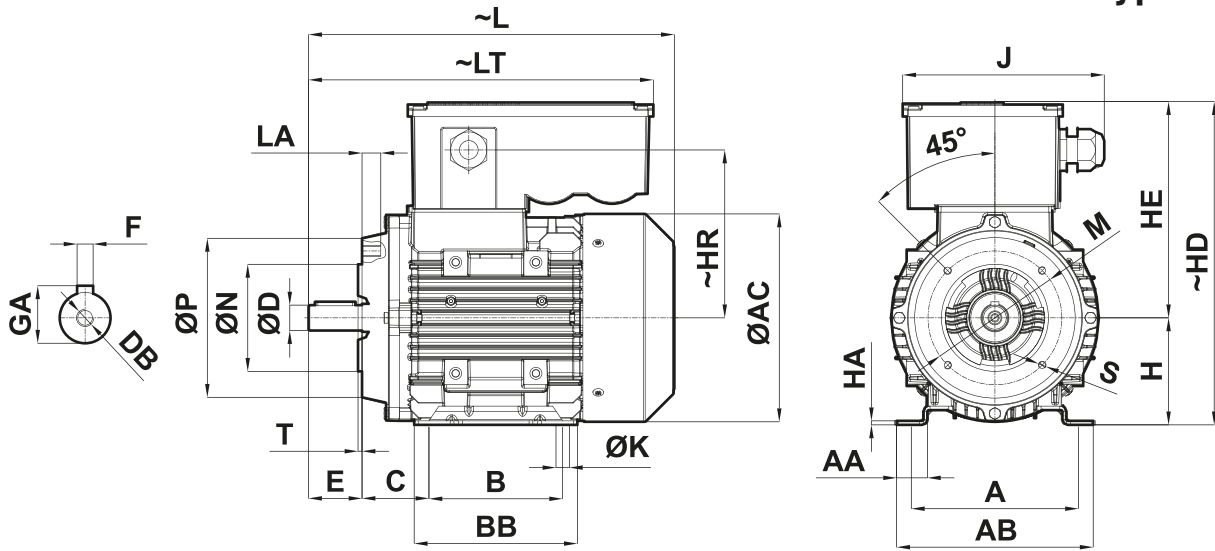

| Frame Size | Number of Poles | D ^[1] | N ^[2] | P | E | T | LA | L | LT | AC | S | M | HR | H ^[3] | HE | HD | F | GA | DB | C | ØK | B | BB | HA | AA | A | AB | J |
|------------|-----------------|------------------|------------------|-----|----|-----|----|-----|-----|-----|----|-----|-----|------------------|-----|-----|---|------|----|----|----|-----|-----|----|----|-----|-----|-----|
| 063M | 2-4 | 11 | 60 | 90 | 23 | 2,5 | 10 | 213 | 208 | 119 | M5 | 75 | 94 | 63 | 160 | 223 | 4 | 12,5 | M4 | 40 | 7 | 80 | 104 | 3 | 18 | 100 | 115 | 128 |
| 071M | 2-4 | 14 | 70 | 105 | 30 | 2,5 | 12 | 242 | 258 | 137 | M6 | 85 | 117 | 71 | 159 | 230 | 5 | 16 | M5 | 45 | 7 | 90 | 110 | 3 | 19 | 112 | 128 | 169 |
| 080M | 2-4 | 19 | 80 | 119 | 40 | 3 | 12 | 274 | 271 | 155 | M6 | 100 | 126 | 80 | 168 | 248 | 6 | 21,5 | M6 | 50 | 10 | 100 | 122 | 3 | 25 | 125 | 148 | 169 |
| 090S | 2-4 | 24 | 95 | 137 | 50 | 3 | 15 | 325 | 304 | 176 | M8 | 115 | 135 | 90 | 177 | 267 | 8 | 27 | M8 | 56 | 10 | 125 | 151 | 4 | 27 | 140 | 167 | 158 |
| 090L | 2-4 | 24 | 95 | 137 | 50 | 3 | 15 | 325 | 304 | 176 | M8 | 115 | 135 | 90 | 177 | 267 | 8 | 27 | M8 | 56 | 10 | 125 | 151 | 4 | 27 | 140 | 167 | 158 |

[1] Tolerance "j6" TS EN 50347

[2] Tolerance "j6" TS EN 50347

[3] Tolerance "-0.5mm" TS EN 50347

Motors with Run and Start Capacitors

B5 – B35 Construction Types

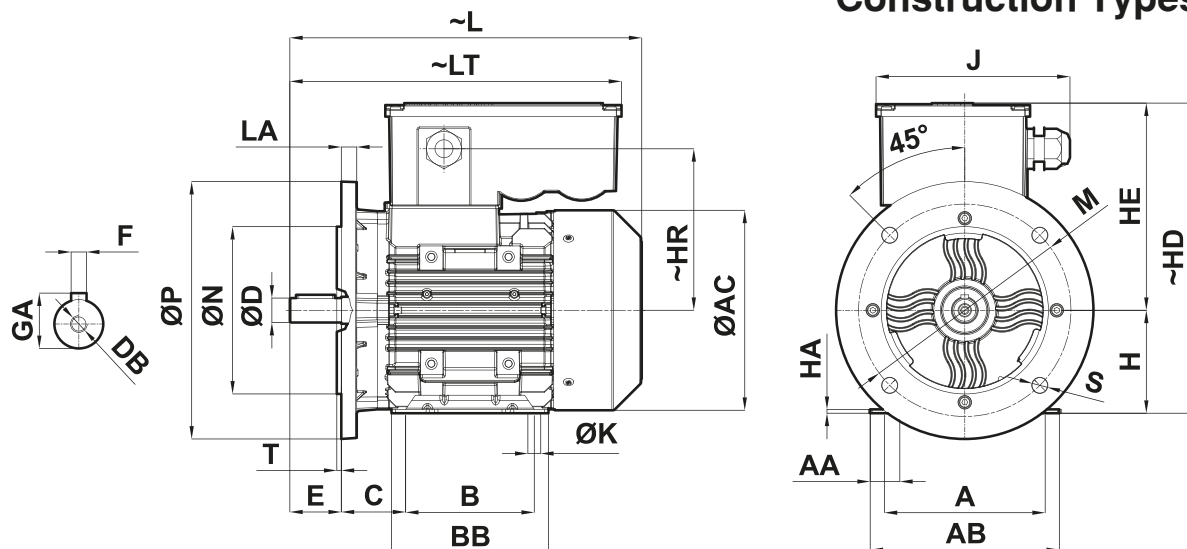

| Frame Size | Number of Poles | D ^[1] | E | N ^[2] | P | T | LA | L | LT | AC | S | M | HR | H ^[3] | HE | HD | F | GA | DB | C | ØK | B | BB | HA | AA | A | AB | J |
|------------|-----------------|------------------|----|------------------|-----|-----|----|-----|-----|-----|----|-----|-----|------------------|-----|-----|---|------|----|----|----|-----|-----|----|----|-----|-----|-----|
| 063M | 2-4 | 11 | 23 | 95 | 140 | 3,0 | 8 | 213 | 208 | 119 | 10 | 115 | 94 | 63 | 160 | 223 | 4 | 12,5 | M4 | 40 | 7 | 80 | 104 | 3 | 18 | 100 | 115 | 128 |
| 071M | 2-4 | 14 | 30 | 110 | 160 | 3,5 | 8 | 242 | 258 | 137 | 10 | 130 | 117 | 71 | 159 | 230 | 5 | 16 | M5 | 45 | 7 | 90 | 110 | 3 | 19 | 112 | 128 | 169 |
| 080M | 2-4 | 19 | 40 | 130 | 200 | 3,5 | 12 | 274 | 271 | 155 | 12 | 165 | 126 | 80 | 168 | 248 | 6 | 21,5 | M6 | 50 | 10 | 100 | 122 | 3 | 25 | 125 | 148 | 169 |
| 090S | 2-4 | 24 | 50 | 130 | 200 | 3,5 | 12 | 325 | 304 | 176 | 12 | 165 | 135 | 90 | 177 | 267 | 8 | 27 | M8 | 56 | 10 | 125 | 151 | 4 | 27 | 140 | 167 | 158 |
| 090L | 2-4 | 24 | 50 | 130 | 200 | 3,5 | 12 | 325 | 304 | 176 | 12 | 165 | 135 | 90 | 177 | 267 | 8 | 27 | M8 | 56 | 10 | 125 | 151 | 4 | 27 | 140 | 167 | 158 |

[1] Tolerance "j6" TS EN 50347

[2] Tolerance "j6" TS EN 50347

[3] Tolerance "-0.5mm" TS EN 50347

Motor Nameplate Example

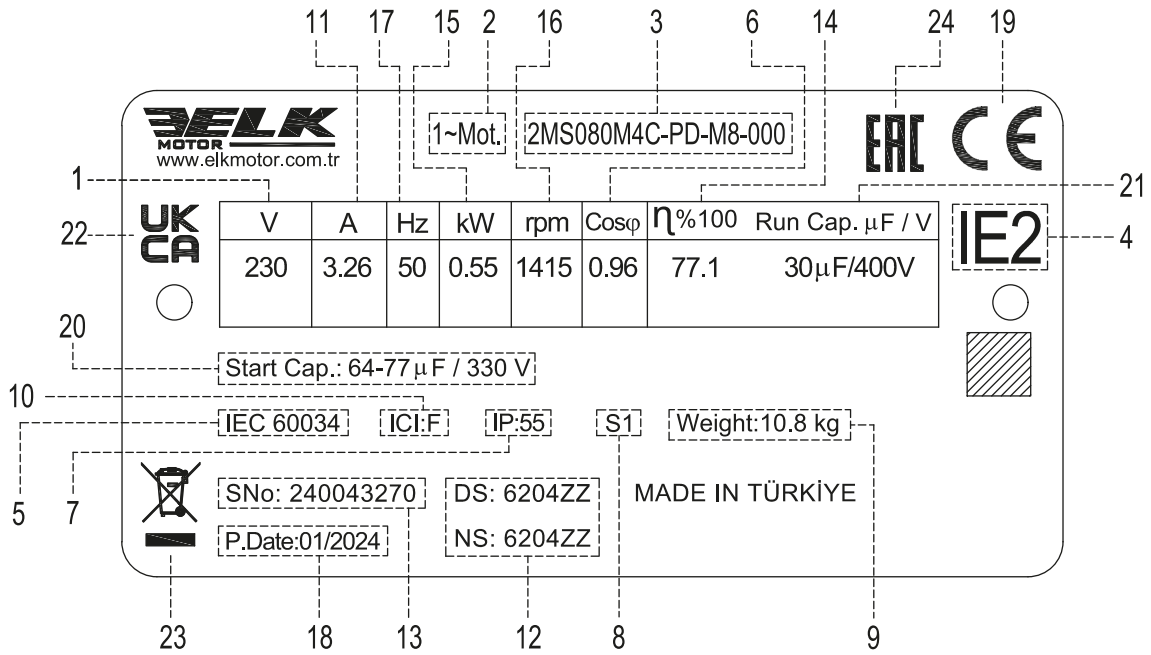

- | | |
|-----------------------------------|------------------------------------|
| 1. Rated Voltage | 13. Serial Number |
| 2. Motor Type: Single Phase Motor | 14. Efficiency |
| 3. Motor Code | 15. Output Power |
| 4. Efficiency Class | 16. Speed |
| 5. Manufacture Standard | 17. Frequency |
| 6. Power Factor | 18. Production Date |
| 7. Protection Class | 19. CE Logo |
| 8. Duty Cycle | 20. Start Capacitor Specifications |
| 9. Motor Weight | 21. Run Capacitor Specifications |
| 10. Insulation Class | 22. UKCA Logo |
| 11. Rated Current | 23. WEEE Symbol |
| 12. Bearing Type | 24. EAC Logo |



The nameplate shows the identification, and the most important technical data. The nameplate also defines the limits of proper usage, and manufacturing year of the motors. The first two digits in the serial number, shows the manufacturing year. For example, 24XXXXXXX shows that the product is manufactured in 2024.

Single-Phase Motor with Run Capacitor Spare Parts

All standard single-phase permanent capacitor motors manufactured by ELK MOTOR consist of the following main components:

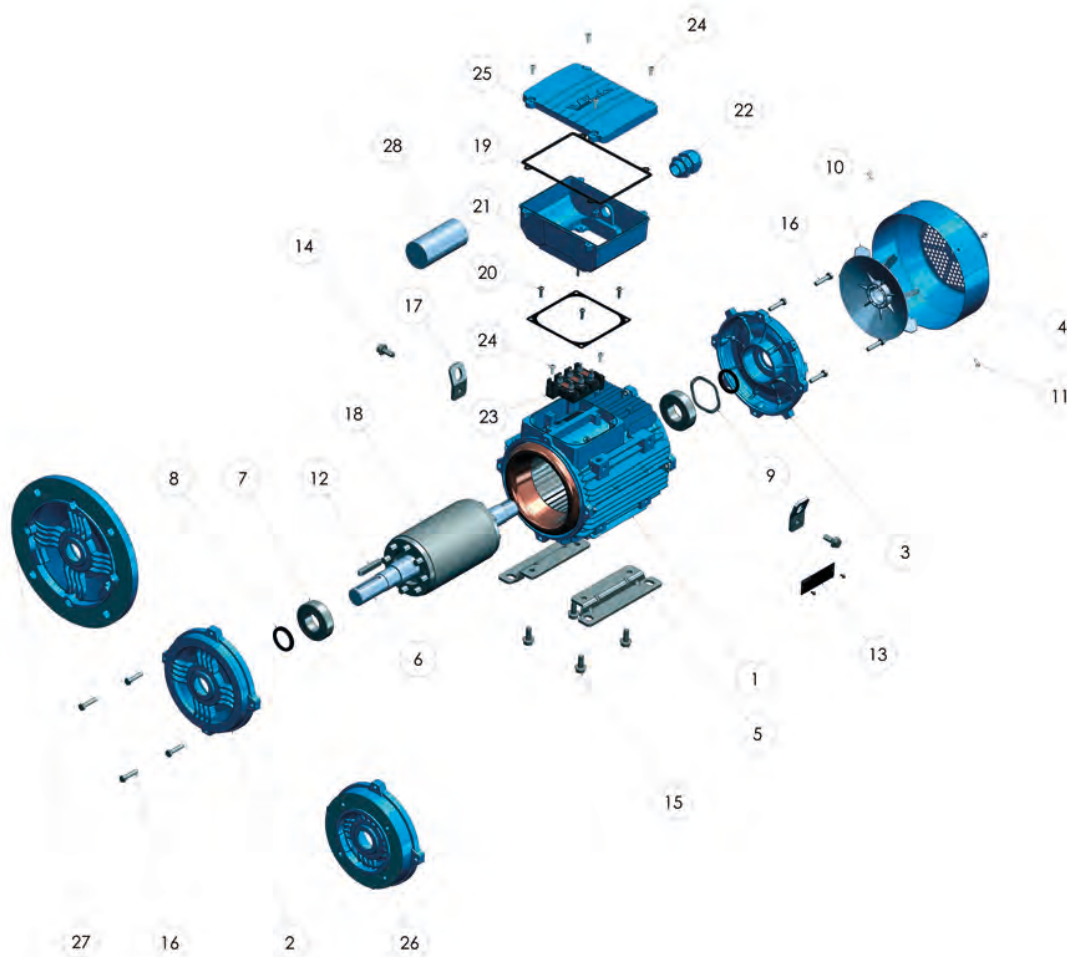

- | | |
|---------------------|-------------------------|
| 1. Housing | 15. Screw |
| 2. End Shield (DE) | 16. Bolt |
| 3. End Shield (NDE) | 17. Lifting Lug |
| 4. Fan Cover | 18. Squirrel Cage Rotor |
| 5. Mounting Foot | 19. Terminal Box Gasket |
| 6. Shaft | 20. Screw |
| 7. Bearing | 21. Terminal Box |
| 8. Shaft Seal | 22. Cable Gland |
| 9. Spring Washer | 23. Terminal |
| 10. Fan | 24. Screw |
| 11. Screw | 25. Terminal Box Cover |
| 12. Key | 26. B14 Flange |
| 13. Nameplate | 27. B5 Flange |
| 14. Screw | 28. Run Capacitor |

While ordering spare parts, the motor serial number, full type designation and product code, as stated on the nameplate, must be specified. For field service, spare parts and additional information, please contact us.

Single-Phase Motor with Run + Start Capacitors Spare Parts

All standard single-phase permanent and start capacitor motors manufactured by ELK MOTOR consist of the following main components:

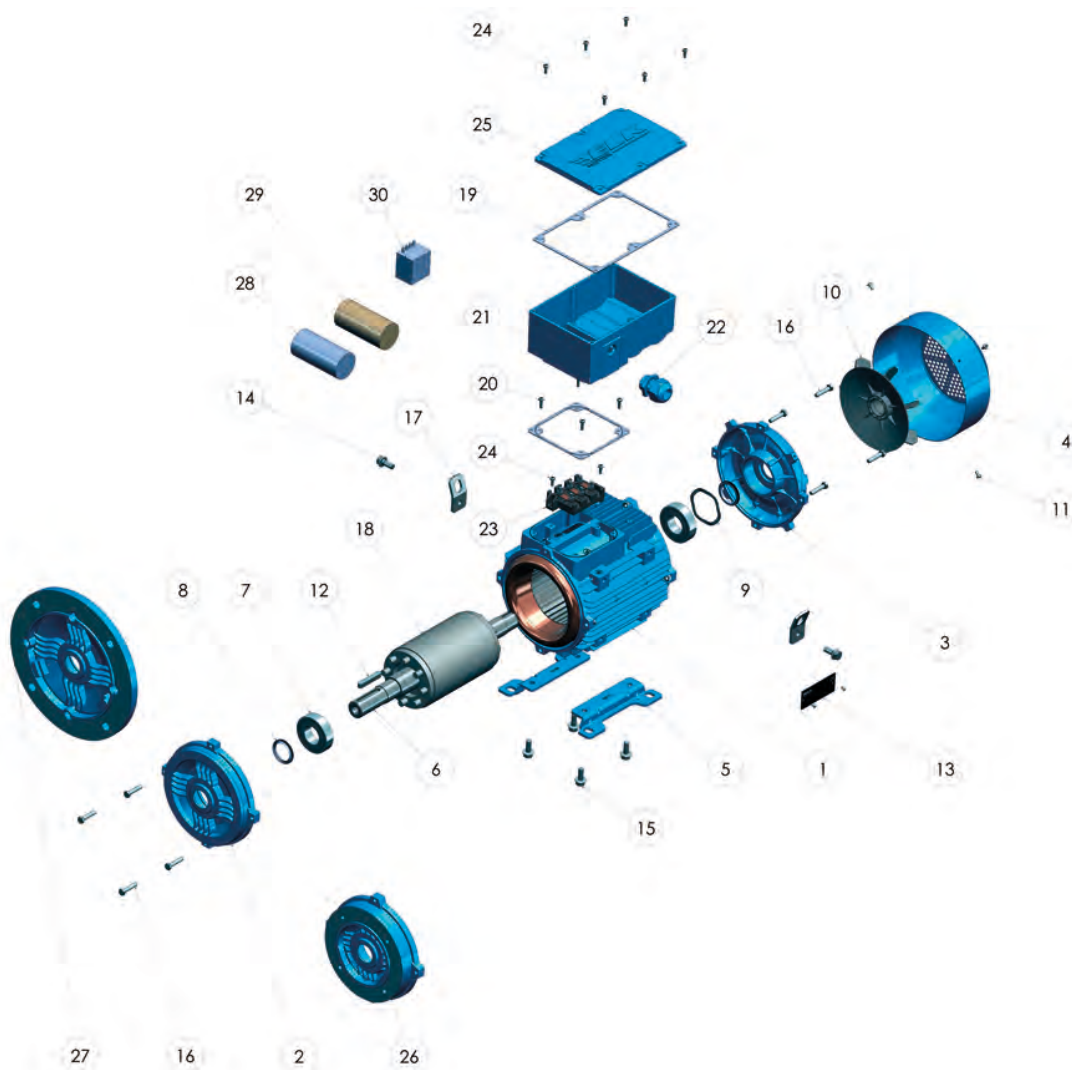

1. Housing

2. End Shield (DE)

3. End Shield (NDE)

4. Fan Cover

5. Mounting Foot

6. Shaft

7. Bearing

8. Shaft Seal

9. Spring Washer

10. Fan

11. Screw

12. Key

13. Nameplate

14. Screw

15. Screw

16. Bolt

17. Lifting Lug

18. Squirrel Cage Rotor

19. Terminal Box Gasket

20. Screw

21. Terminal Box

22. Cable Gland

23. Terminal

24. Screw

25. Terminal Box Cover

26. B14 Flange

27. B5 Flange

28. Run Capacitor

29. Start Capacitor

30. Starter Relay

While ordering spare parts, the motor serial number, full type designation and product code, as stated on the nameplate, must be specified. For field service, spare parts and additional information, please contact us.

EXPROOF MOTORS



**Technical
Specifications**

Overview

Electrical equipment and devices can pose risks to the environment and human health when they come into contact with flammable and explosive substances such as fumes, dust, and smoke present in the surroundings. To ensure maximum safety, international ATEX regulations and standards have been implemented to define the essential health and safety requirements and conformity assessment procedures for equipment and protective systems used in potentially explosive environments. Exproof equipment is designed to prevent explosions when used correctly. These devices can be designed to meet various protection types. The types of protection and areas are determined based on the likelihood of the presence of a potentially explosive atmosphere. Equipment categories are assigned to these areas, which are then subdivided into potential protection types and thus into potential equipment (product) types. Depending on the specific area and related hazard, operational equipment must comply with the minimum requirements specified for the protection type. Different protection types require specific measures to prevent ignition and ensure safety in environments with explosive atmospheres.

Typical Applications

Oil and Gas Industry
 Chemical industry
 Pharmaceutical industry
 Oil and petrochemical plants
 Food and Beverage Industry
 Paint and Coating Industry
 Natural gas facilities
 Wastewater Treatment Plants
 Iron-steel industry

**Proper motor selection according to the application's needs is the responsibility of the application/system engineer.*

IEC/EN Compatibility

All of standard ELK Motors are designed, manufactured and tested according to the IEC and EN standards given below.



| | | |
|----------------|--|-------------------------|
| IEC 60079-0 | General Terms | } Explosive atmospheres |
| IEC 60079-7 | Increased Safety "e" | |
| IEC 60079-31 | Equipment Dust Ignition Protection by Enclosure "t" | |
| IEC 60034-1 | Rating and Performance | |
| IEC 60034-2-1 | Determining Losses and Efficiency From Tests | |
| IEC 60034-5 | Protection Degree Classification (IP) | |
| IEC 60034-6 | Cooling Methods | |
| IEC 60034-7 | Classification of Construction Types and Mounting Arrangements | |
| IEC 60034-8 | Terminal Markings and Direction of Rotation | |
| IEC 60034-9 | Noise Limits | |
| IEC 60034-11 | Thermal Protection | |
| IEC 60034-14 | Mesurement, Evaluation and Limits of Vibration Severity | |
| IEC 60034-18-1 | Functional evolution of Insulation System | |
| IEC 60034-30 | Efficiency Classes (IE Code) | |
| IEC 60038 | Standard Voltages | |
| EN 50347 | Standart Dimensions and Output Powers | |
| EN 55014-1 | } Electromagnetic Compatibility | |
| EN 61000-3-2 | | |
| EN 61000-3-3 | | |

According to IEC 60034-1, catalogue values are permitted to deviate from the real values as follows:

| | |
|---|--|
| Motor Speed (n) | $\Delta n = \pm 20\% (n_s - n_N), P_N \geq 1 \text{ kW}$ $\Delta n = \pm 30\% (n_s - n_N), P_N < 1 \text{ kW}$ |
| Efficiency %(\eta) | $\Delta \eta = -15\% (100 - \eta_N)$ |
| Power factor (\phi) | $\text{Cos} \phi = -1/6 (1 - \text{Cos} \phi)$ |
| Locked rotor current (I_{L,N}) | $\Delta (I_{L,N}) = +20\% (I_{L,N})$ |
| Starting torque (M_L/M_N) | min. (M _L /M _N) = -15% (M _L /M _N) max. (M _L /M _N) = +25% (M _L /M _N) |
| Breakdown torque (M_K/M_N) | (M _K /M _N) = -10% (M _K /M _N) |
| Moment of inertia (J) [kgm²] | $\Delta J = \pm 10\% J$ |
| Sound pressure level (L_{PA}) [dB(A)] | L _{PA} = +3 dB (A) |

Explosive Atmospheres Protection Directive 2014/34/EU

Explosion protection has been fully aligned with Directive 2014/34/EU. The requirements of the new regulation came into effect on April 20, 2016. Since that date, only devices and protection systems compliant with Directive 2014/34/EU are permitted to be placed on the market. Directive 2014/34/EU and Directive 1999/92/EC specify that only certain electrical equipment and devices are permitted in designated zones. Devices are assigned to equipment groups and categories.

| | | | | | | | | | | | |
|--|---|------|---|----|---|---|----|----|------|---------------|----|
| Example |  | 2284 |  | II | 3 | G | Ex | ec | IIC | T4 | Gc |
| Increased Protection | | | | II | 3 | D | Ex | tc | IIIC | T120°C-T140°C | Dc |
| CE marking | | | | | | | | | | | |
| Notified Body Number | | | | | | | | | | | |
| Symbol for Explosion Protection | | | | | | | | | | | |
| Equipment Group | I: Mining II: Non-mining | | | | | | | | | | |
| Equipment Category | 2: Zone 1/21 3: Zone 2/22 | | | | | | | | | | |
| Environment | G: Gas D: Dust | | | | | | | | | | |
| Explosion Protection | | | | | | | | | | | |
| Type of Protection | Ex db, db eb, eb, ec, tb veya tc | | | | | | | | | | |
| Environment Sub Category | II: Gas (IIA, IIB veya IIC) III: Dust (IIIA, IIIB veya IIIC) | | | | | | | | | | |
| Temperature Class (Maximum Surface Temperature) | | | | | | | | | | | |
| T1 = 450 °C T4 = 135 °C | | | | | | | | | | | |
| T2 = 300 °C T5 = 100 °C | | | | | | | | | | | |
| T3 = 200 °C T6 = 85 °C | | | | | | | | | | | |
| Equipment Protection Level (G: Gas - D: Dust) | | | | | | | | | | | |
| Ga: Very High Protection Da: Very High Protection | | | | | | | | | | | |
| Gb: High Protection Db: High Protection | | | | | | | | | | | |
| Gc: Enhanced Protection Dc: Enhanced Protection | | | | | | | | | | | |

Electrical Construction

Our Exproof motors feature an F-class (155°C) Insulation Class. Additionally, all Zone 2/22 motors in our product range remain within the B-class Temperature Rise limits.

Electrical Connections

| Cable Gland | | | | | | | | | | | | | | |
|--------------|-------------|---------------------------|----------------------------|----|-----|-------------|-----|---------------------------|-----|---------------------------|-----|-------------|-----|-----|
| Frame Size | 63 | 71 | 80 | 90 | 100 | 112 | 132 | 160 | 180 | 200 | 225 | 250 | 280 | 315 |
| Cable Glands | 2 x M16x1,5 | 1 x M20x1,5 + 1 x M16x1,5 | 1 x M20x1,5 1 x M25x1,5 | | | 2 x M32x1,5 | | 1 x M40x1,5 + 1 x M12x1,5 | | 1 x M50x1,5 + 1 x M12x1,5 | | 2 x M63x1,5 | | |

The cable glands are Ex-certified and unarmored. They can be provided with armor upon request.

| Terminal Connections | | | | | | | | | | | | | | |
|----------------------|-----|-----|-----|-----|-----|-----|-----|-----|-----|-----|-----|-----|-----|-----|
| Frame Size | 063 | 071 | 080 | 090 | 100 | 112 | 132 | 160 | 180 | 200 | 225 | 250 | 280 | 315 |
| Terminal Size | M4 | | | | M5 | | | M6 | | | M8 | M10 | | M16 |

Three-phase EX motors should be connected in either star or delta configuration, depending on the voltage specified on the motor nameplate and the supply voltage. Motors with a 230/400V nameplate should be connected in star configuration, while motors with a 400/690V nameplate should be connected in delta configuration on a 400V network. Star-Delta starting can also be applied to 400/690V motors on a 400V network. The terminal connections for three-phase motors are provided below.

Terminal Connections for Three-Phase Motors

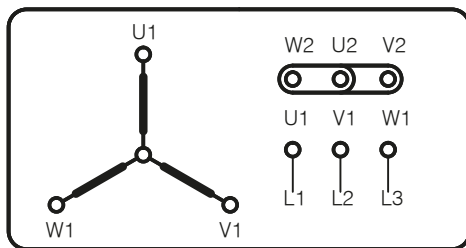

Y Star Connection
Clockwise Rotation

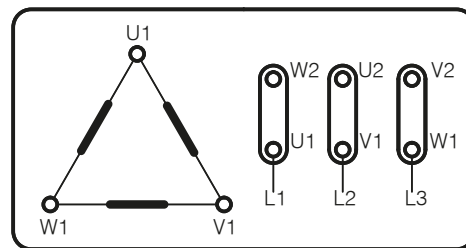

Δ Delta Connection
Clockwise Rotation

Standard ELK motors are manufactured to rotate clockwise. To change the direction of rotation, the positions of any two phases on the terminal can be swapped. For an illustrative example, refer to the schematic below.

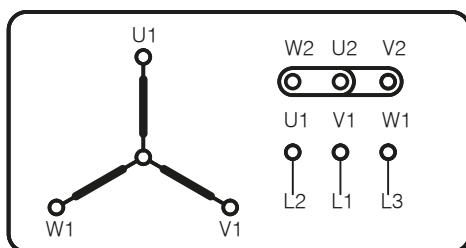

Y Star Connection
Counter-clockwise Rotation

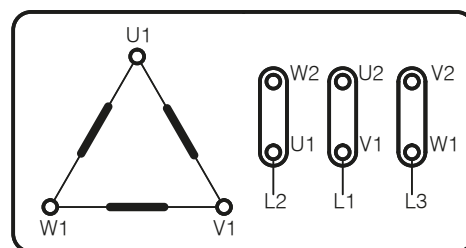

Δ Delta Connection
Counter-clockwise Rotation

Winding Insulation / Temperature Rise Classes

INSULATION CLASS

Maximum Winding Temperature

Tolerance

Limits of Winding Temperature

Ambient Temperature

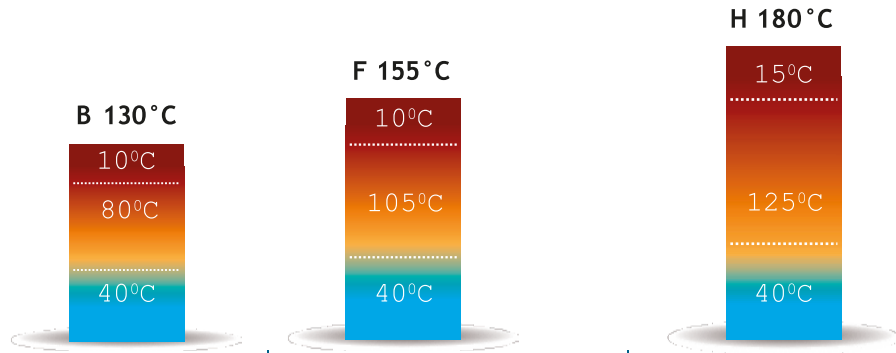

B

Class B insulation system is shown for reference purposes only. Class B insulation system is not used in ELK motor.

F (Standart)

Our standard motors have class F electrical insulation system. The maximum permissible winding temperature at 40°C ambient temperature is 155°C.

H (Optional)

H class insulation is provided on special request. At 40°C ambient temperature, the maximum permissible winding temperature is 180°C

Protection Classes

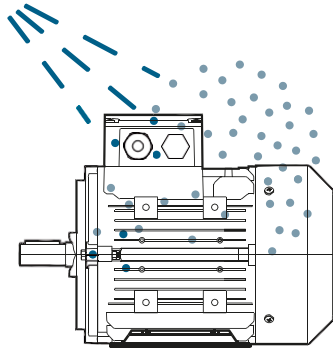

IP55 (Standart)

Limited protection against dust ingress and protected against low pressure water jets from any directio.

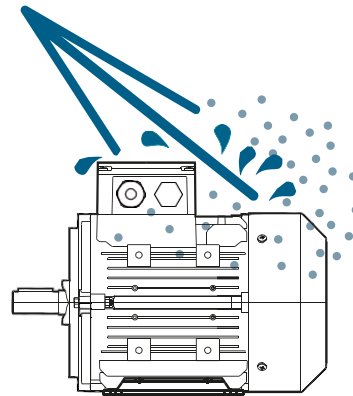

IP56

Limited protection against dust ingress and protected against high pressure water jets from any direction.

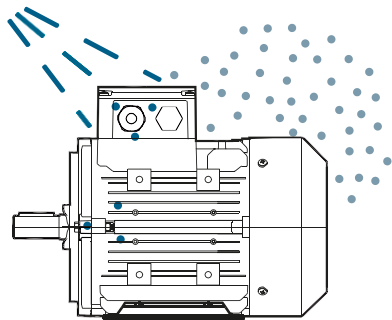

IP65

Totally protected against dust ingress and protected against low pressure water jets from any direction.

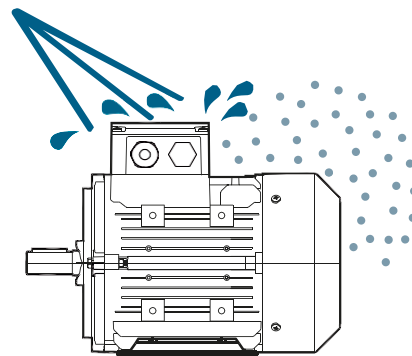

IP66

Totally protected against dust ingress and protected against high pressure water jets from any direction.

Mechanical Construction

Exproof ELK motors feature a removable foot structure for all frame sizes, with the feet capable of being attached to three sides of the frame. This allows users to adjust the foot position to easily configure the terminal box to be on the right, top, or left side of the motor. In standard motors, the terminal box is positioned at the top.

FRAME SIZE 63-315

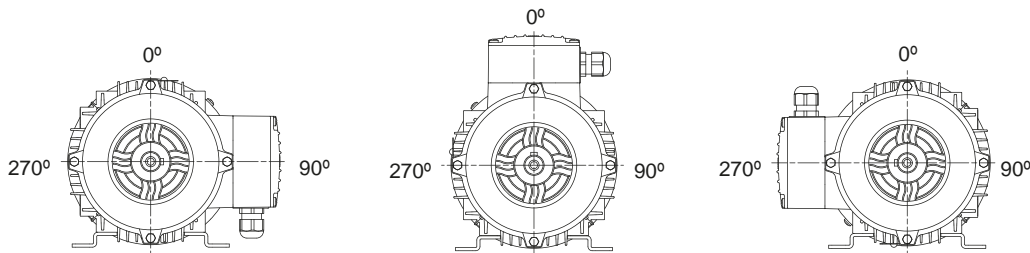

Additionally, Exproof ELK motors, thanks to their symmetrical frame and foot design, maintain a constant C dimension when the DE end-shield, NDE end-shield, and shaft direction are changed. This allows the terminal box to be positioned either close to the DE side or close to the NDE (fan) side.

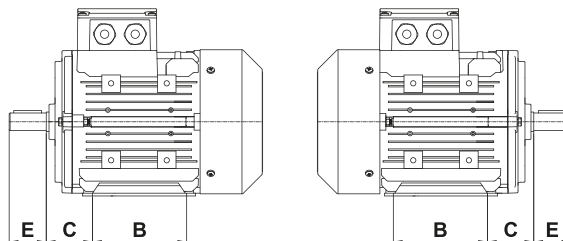

The raw materials that are used in our motors depending on the frame size are listed below.

| Frame Size | Housing | End Shield DE | End Shield NDE | Terminal Box & Cover | Feet | Fan Cover | Fan* |
|------------|-----------|---------------|----------------|----------------------|-------------|-------------|---------|
| 63 | Aluminum | Aluminum | Aluminum | Aluminum | Steel Sheet | Steel Sheet | Plastic |
| 71 | Aluminum | Aluminum | Aluminum | Aluminum | Steel Sheet | Steel Sheet | Plastic |
| 80 | Aluminum | Aluminum | Aluminum | Aluminum | Steel Sheet | Steel Sheet | Plastic |
| 90 | Aluminum | Aluminum | Aluminum | Aluminum | Steel Sheet | Steel Sheet | Plastic |
| 100 | Aluminum | Aluminum | Aluminum | Aluminum | Steel Sheet | Steel Sheet | Plastic |
| 112 | Aluminum | Aluminum | Aluminum | Aluminum | Steel Sheet | Steel Sheet | Plastic |
| 132 | Aluminum | Aluminum | Aluminum | Aluminum | Steel Sheet | Steel Sheet | Plastic |
| | Cast Iron | Cast Iron | Cast Iron | Cast Iron | Cast Iron | Steel Sheet | |
| 160 | Aluminum | Aluminum | Aluminum | Aluminum | Aluminum | Steel Sheet | Plastic |
| | Cast Iron | Cast Iron | Cast Iron | Cast Iron | Cast Iron | Steel Sheet | |
| 180 | Aluminum | Aluminum | Aluminum | Aluminum | Aluminum | Steel Sheet | Plastic |
| | Cast Iron | Cast Iron | Cast Iron | Cast Iron | Cast Iron | Steel Sheet | |
| 200 | Aluminum | Aluminum | Aluminum | Aluminum | Aluminum | Steel Sheet | Plastic |
| | Cast Iron | Cast Iron | Cast Iron | Cast Iron | Cast Iron | Steel Sheet | |
| 225 | Aluminum | Aluminum | Aluminum | Aluminum | Aluminum | Steel Sheet | Plastic |
| | Cast Iron | Cast Iron | Cast Iron | Cast Iron | Cast Iron | Steel Sheet | |
| 250 | Cast Iron | Cast Iron | Cast Iron | Cast Iron | Cast Iron | Steel Sheet | Plastic |
| 280 | Cast Iron | Cast Iron | Cast Iron | Cast Iron | Cast Iron | Steel Sheet | Plastic |
| 315 | Cast Iron | Cast Iron | Cast Iron | Cast Iron | Cast Iron | Steel Sheet | Plastic |

* The fan material is flame retardant (V0), antistatic, and halogen-free, in compliance with the relevant standards.

Construction Types

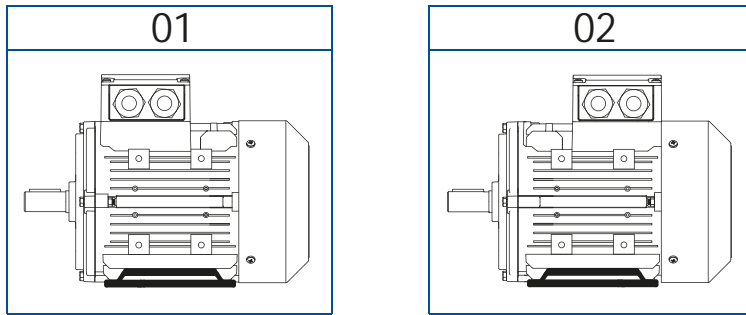

Exproof ELK motors can be positioned with the terminal box on the drive side or the fan side. Depending on these options, the motor foot and cable gland orientation options are as shown in the table.

01: Terminal box on the drive side
02: Terminal box on the fan side

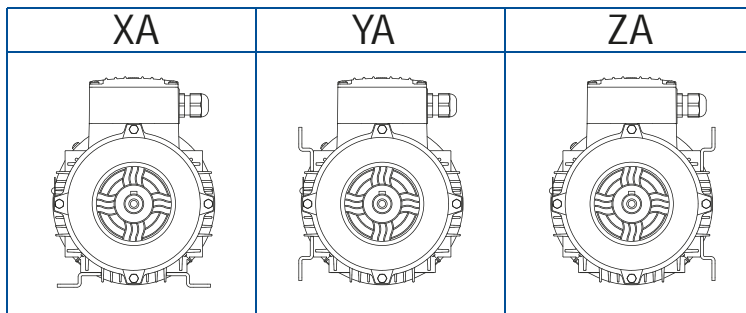

X: Feet on the ground when viewed from the drive side

Y: Feet on the left when viewed from the drive side

Z: Feet on the right when viewed from the drive side

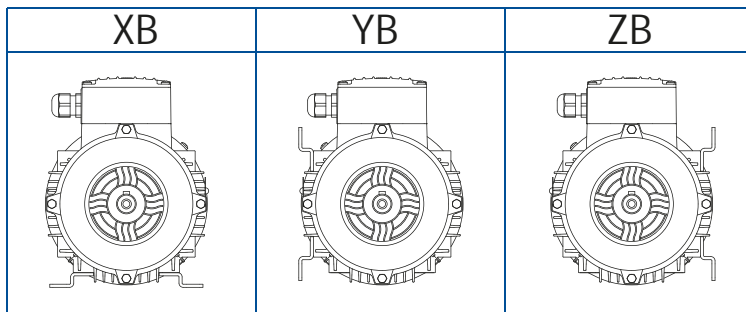

A: Cable gland on the right when viewed from the drive side

B: Cable gland on the left when viewed from the drive side

C: Cable gland at the back when viewed from the drive side

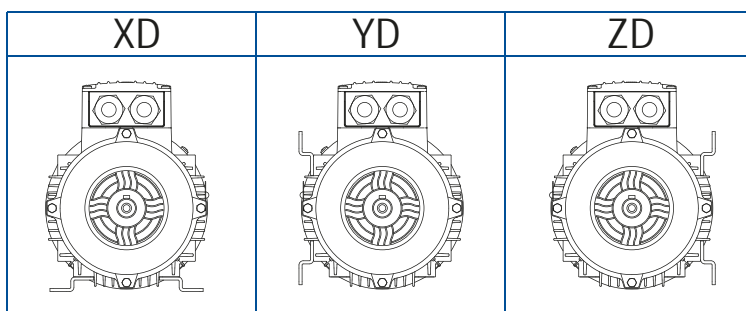
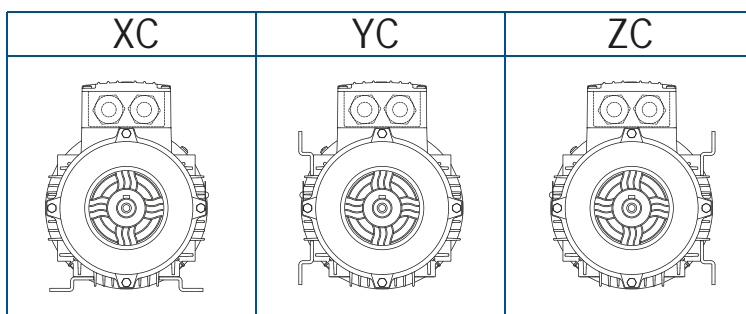

D: Cable gland at the front when viewed from the drive side



In cases where feet are not required on the motor, mounting positions other than X, Y, and Z are applicable.

Construction Types

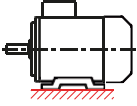
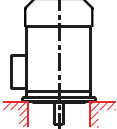
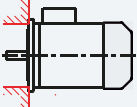
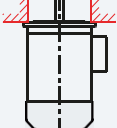
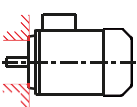
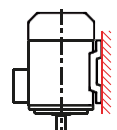
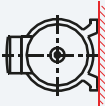
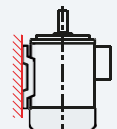
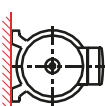
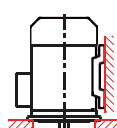
Exproof ELK motors are manufactured in accordance with international mounting standards IEC 60034-7.

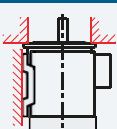
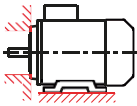
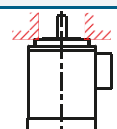
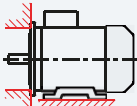
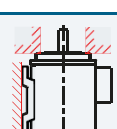
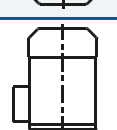
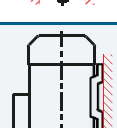
| Mounting Codes and Diagrams According to IEC 60034-7 | | | | | |
|---|--------|---------|---|--------|---------|
| Horizontal Mounting Codes | | | Vertical Mounting Codes | | |
| | I | II | | I | II |
|  | IM B3 | IM 1001 |  | IM V1 | IM 3011 |
|  | IM B5 | IM 3001 |  | IM V3 | IM 3031 |
|  | IM B14 | IM 3601 |  | IM V5 | IM 1011 |
|  | IM B7 | IM 1061 |  | IM V6 | IM 1031 |
|  | IM B6 | IM 1051 |  | IM V15 | IM 2011 |
|  | IM B8 | IM 1071 |  | IM V35 | IM 2031 |
|  | IM B34 | IM 2101 |  | IM V19 | IM 3631 |
|  | IM B35 | IM 2001 |  | IM V37 | IM 2131 |
| | | |  | IM V18 | IM 3611 |
| | | |  | IM V17 | IM 2111 |

Bearings

Ex ELK motors use the deep groove ball bearings specified in the table. Cylindrical roller bearings (NUP) are optional.

| Frame Size | Number of Poles | End Shield DE | End Shield NDE |
|------------|-----------------|---------------|----------------|
| 63 | 2-4-6-8 | 6201 ZZ C3 | 6201 ZZ C3 |
| 71 | 2-4-6-8 | 6202 ZZ C3 | 6202 ZZ C3 |
| 80 | 2-4-6-8 | 6204 ZZ C3 | 6204 ZZ C3 |
| 90 | 2-4-6-8 | 6205 ZZ C3 | 6205 ZZ C3 |
| 100 | 2-4-6-8 | 6206 ZZ C3 | 6206 ZZ C3 |
| 112 | 2-4-6-8 | 6206 ZZ C3 | 6206 ZZ C3 |
| 132 | 2-4-6-8 | 6208 ZZ C3 | 6208 ZZ C3 |
| 160 | 2-4-6-8 | 6309 ZZ C3 | 6209 ZZ C3 |
| 180 | 2-4-6-8 | 6310 ZZ C3 | 6210 ZZ C3 |
| 200 | 2-4-6-8 | 6312 ZZ C3 | 6212 ZZ C3 |
| 225 | 2-4-6-8 | 6313 ZZ C3 | 6213 ZZ C3 |
| 250 | 2-4-6-8 | 6315 ZZ C3 | 6215 ZZ C3 |
| 280 | 2 | 6315 C3 | 6315 C3 |
| | 4-6-8 | 6317 C3 | 6317 C3 |
| 315 | 2 | 6316 C3 | 6316 C3 |
| | 4-6-8 | 6319 C3 | 6319 C3 |

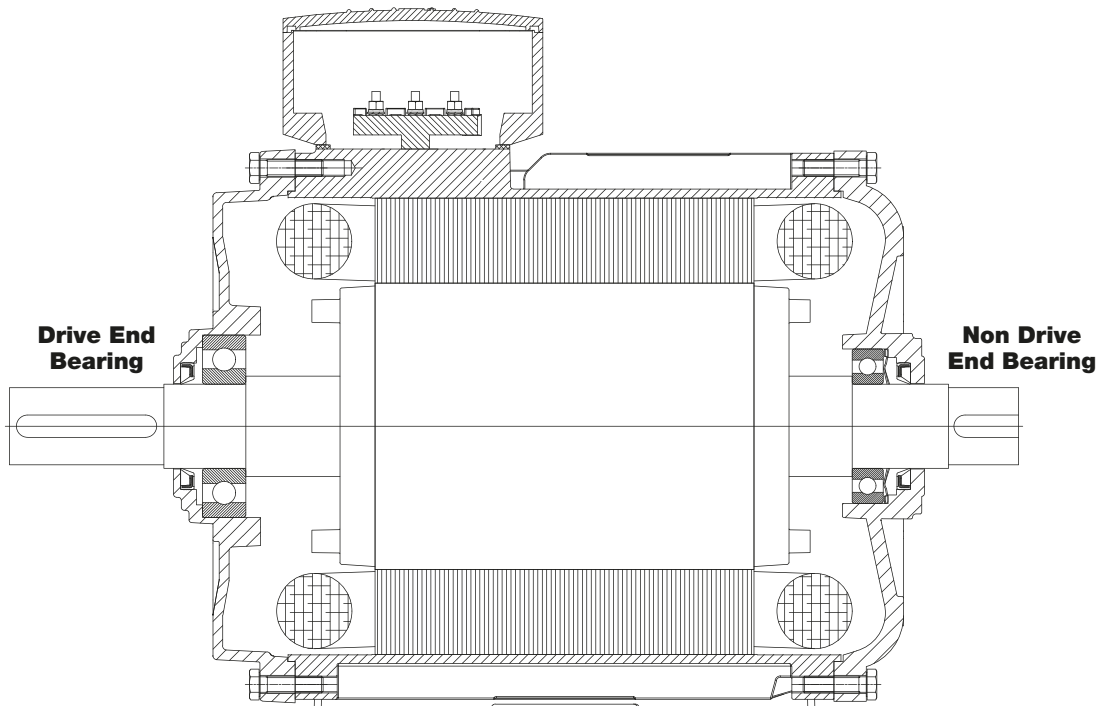

Radial Loads

Radial Load on the Shaft (FR):

The radial load on the shaft can be calculated using the formula below.

The calculated radial load must not exceed the permissible values specified in the tables ($FR < Fr_x$). If it does, please consult us.

$$F_R = k \cdot \frac{P}{D \cdot n} \cdot 10^7 \text{ (N)}$$

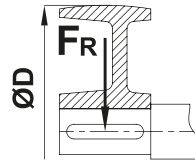

Correction of the Permissible Radial Load (Fr_x):

If the radial load acting on the shaft is between points x_0 and x_{max} , the permissible value should be corrected using the following formula.

$$Fr_x = Fr_0 - \frac{x}{E} (Fr_0 - Fr_{max})$$

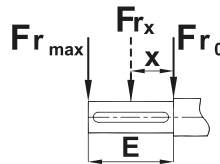

P: Motor Power (kW)

D: Shaft Diameter (mm)

n: Motor Speed (rpm)

k: Radial Load Factor

- Spur Gears, chain drives with low speed = 2.1
- Trigger Belts = 2.5
- V type belts = 5

$FR < Fr_x$: The radial load on the shaft must be less than the permissible maximum radial load.

F_a : Axial load acting on the shaft.

Fr_0 : Permissible maximum radial load on the shaft.

Fr_{max} : Permissible maximum radial load at the end of the shaft.

Permissible load calculations are based on bearing lifetimes according to ISO 281, with an L_{h10} of 20,000 hours.

Radial Loads

HORIZONTAL MOUNTING - Permissible Radial Loads
 Mounting Positions IM: B3, B5, B6, B7, B8, B14, B34, B35

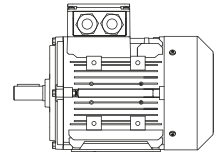

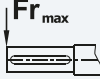
| Frame Size | Fa = 0 | |
|-----------------------------|---|---|
| |  |  |
| 2 Poles 3000 rpm | Fr₀ [N] | Fr_{max} [N] |
| 63 | 350 | 300 |
| 71 | 380 | 340 |
| 80 | 640 | 550 |
| 90 | 750 | 660 |
| 100 | 1050 | 900 |
| 112 | 1050 | 910 |
| 132 | 1520 | 1220 |
| 160 | 2800 | 2300 |
| 180 | 3250 | 2650 |
| 200 | 4340 | 3560 |
| 225 | 4950 | 4000 |
| 250 | 6050 | 4800 |
| 280 | 6300 | 5100 |
| 315 | 6400 | 5550 |
| 4 Poles 1500 d/d | Fr₀ [N] | Fr_{max} [N] |
| 63 | 430 | 390 |
| 71 | 520 | 440 |
| 80 | 800 | 700 |
| 90 | 950 | 780 |
| 100 | 1300 | 1050 |
| 112 | 1300 | 1050 |
| 132 | 1950 | 1600 |
| 160 | 3540 | 2825 |
| 180 | 4100 | 3400 |
| 200 | 5500 | 4550 |
| 225 | 6200 | 4900 |
| 250 | 7500 | 6000 |
| 280 | 8200 | 7500 |
| 315 | 8500 | 8000 |
| 6 Poles 1000 d/d | Fr₀ [N] | Fr_{max} [N] |
| 71 | 580 | 500 |
| 80 | 870 | 800 |
| 90 | 1090 | 900 |
| 100 | 1500 | 1250 |
| 112 | 1500 | 1250 |
| 132 | 2200 | 1800 |
| 160 | 4050 | 3190 |
| 180 | 4720 | 3830 |
| 200 | 6350 | 5150 |
| 225 | 7350 | 5650 |
| 250 | 8950 | 7200 |
| 280 | 9500 | 8500 |
| 315 | 9800 | 8700 |

Fa0 : Permissible maximum axial load

Fr : Radial force acting on the shaft

Fr0 : Permissible maximum radial load at the end of the shaft





Fr max : Permissible maximum radial load at the shaft end

Permissible load calculations are based on a bearing life of Lh10 20,000 hours according to ISO 281.

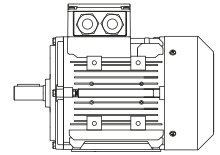
Axial Loads

HORIZONTAL MOUNTING - Permissible Axial Loads
 Mounting Positions IM: B3, B5, B6, B7, B8, B14, B34, B35

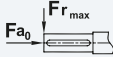

| Frame Size | Push | | | Pull |
|-----------------------------|---|---|---|---|
| | Fr = 0 | Fr = Fr ₀ | Fr = Fr _{max} | Fr = 0 |
| |  |  |  |  |
| 2 Poles 3000 rpm | Fa₀ [N] | Fa₀ [N] | Fa₀ [N] | Fa₀ [N] |
| 63 | 90 | 90 | 90 | 220 |
| 71 | 110 | 110 | 110 | 250 |
| 80 | 190 | 190 | 190 | 395 |
| 90 | 210 | 210 | 210 | 400 |
| 100 | 270 | 270 | 270 | 580 |
| 112 | 270 | 270 | 270 | 580 |
| 132 | 380 | 380 | 370 | 800 |
| 160 | 2280 | 1060 | 1020 | 1670 |
| 180 | 2660 | 1250 | 1250 | 1970 |
| 200 | 3150 | 1500 | 1390 | 2600 |
| 225 | 3850 | 1850 | 1760 | 2750 |
| 250 | 4150 | 2180 | 2250 | 3350 |
| 280 | 4500 | 2500 | 2500 | 3350 |
| 315 | 5200 | 2700 | 2700 | 3410 |
| 4 Poles 1500 rpm | Fa₀ [N] | Fa₀ [N] | Fa₀ [N] | Fa₀ [N] |
| 63 | 90 | 90 | 90 | 330 |
| 71 | 110 | 110 | 110 | 360 |
| 80 | 190 | 190 | 190 | 560 |
| 90 | 210 | 210 | 210 | 585 |
| 100 | 300 | 300 | 300 | 830 |
| 112 | 300 | 300 | 300 | 830 |
| 132 | 400 | 400 | 400 | 1200 |
| 160 | 2280 | 1400 | 1400 | 2350 |
| 180 | 3100 | 1570 | 1500 | 2800 |
| 200 | 4400 | 1770 | 1770 | 3810 |
| 225 | 4950 | 2150 | 2200 | 4300 |
| 250 | 6050 | 2400 | 2400 | 4500 |
| 280 | 7200 | 3000 | 3000 | 5500 |
| 315 | 7800 | 4000 | 3700 | 5800 |
| 6 Poles 1000 rpm | Fa₀ [N] | Fa₀ [N] | Fa₀ [N] | Fa₀ [N] |
| 71 | 110 | 110 | 110 | 430 |
| 80 | 190 | 190 | 190 | 700 |
| 90 | 210 | 210 | 210 | 740 |
| 100 | 290 | 290 | 290 | 1020 |
| 112 | 290 | 290 | 290 | 1020 |
| 132 | 380 | 380 | 380 | 1470 |
| 160 | 3050 | 1540 | 1520 | 2900 |
| 180 | 3540 | 1780 | 1700 | 3410 |
| 200 | 4800 | 2200 | 2250 | 4400 |
| 225 | 5050 | 2580 | 2800 | 5200 |
| 250 | 6050 | 3100 | 3150 | 6500 |
| 280 | 7000 | 3700 | 3400 | 7150 |
| 315 | 8500 | 4200 | 3800 | 6900 |

Fa₀ : Permissible maximum axial load

Fr : Radial force acting on the shaft

Fr₀ : Permissible maximum radial load at the end of the shaft



Fr_{max} : Permissible maximum radial load at the shaft end

Permissible load calculations are based on a bearing life of L_{h10} 20,000 hours according to ISO 281.

Axial Loads

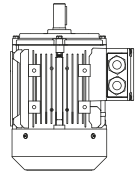
VERTICAL MOUNTING - Shaft Up - Permissible Axial Loads
Mounting Positions IM: V3, V6, V19, V35, V37

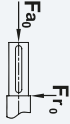
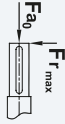

| Frame Size | Push | | | Pull |
|-----------------------------|---|---|---|---|
| | Fr = 0 | Fr = Fr ₀ | Fr = Fr _{max} | Fr = 0 |
| |  |  |  |  |
| 2 Poles 3000 rpm | Fa₀ [N] | Fa₀ [N] | Fa₀ [N] | Fa₀ [N] |
| 63 | 90 | 90 | 90 | 230 |
| 71 | 100 | 100 | 100 | 265 |
| 80 | 170 | 170 | 170 | 425 |
| 90 | 180 | 180 | 180 | 450 |
| 100 | 250 | 250 | 250 | 650 |
| 112 | 250 | 250 | 250 | 660 |
| 132 | 300 | 300 | 300 | 970 |
| 160 | 2080 | 1060 | 990 | 1950 |
| 180 | 2410 | 1190 | 1050 | 2350 |
| 200 | 2900 | 1265 | 1265 | 3000 |
| 225 | 3250 | 1310 | 1295 | 3575 |
| 250 | 3950 | 1460 | 1450 | 4350 |
| 280 | 4100 | 1500 | 1500 | 4700 |
| 315 | 4380 | 1420 | 1420 | 5250 |
| 4 Poles 1500 rpm | Fa₀ [N] | Fa₀ [N] | Fa₀ [N] | Fa₀ [N] |
| 63 | 90 | 90 | 90 | 345 |
| 71 | 95 | 95 | 95 | 380 |
| 80 | 160 | 160 | 160 | 600 |
| 90 | 170 | 170 | 170 | 650 |
| 100 | 210 | 210 | 210 | 930 |
| 112 | 210 | 210 | 210 | 950 |
| 132 | 240 | 240 | 240 | 1430 |
| 160 | 2500 | 1250 | 1220 | 2160 |
| 180 | 2900 | 1400 | 1370 | 2570 |
| 200 | 3900 | 1360 | 1530 | 3500 |
| 225 | 4450 | 1570 | 1680 | 4000 |
| 250 | 5400 | 1870 | 1910 | 4300 |
| 280 | 6500 | 2250 | 2250 | 7100 |
| 315 | 6000 | 2050 | 1600 | 8850 |
| 6 Poles 1000 rpm | Fa₀ [N] | Fa₀ [N] | Fa₀ [N] | Fa₀ [N] |
| 71 | 95 | 95 | 95 | 455 |
| 80 | 160 | 160 | 160 | 745 |
| 90 | 170 | 170 | 170 | 800 |
| 100 | 230 | 230 | 230 | 1120 |
| 112 | 210 | 210 | 210 | 1150 |
| 132 | 250 | 250 | 250 | 1690 |
| 160 | 2980 | 1490 | 1450 | 3300 |
| 180 | 3400 | 1670 | 1670 | 3800 |
| 200 | 4250 | 1850 | 1860 | 5100 |
| 225 | 4800 | 1980 | 2080 | 5800 |
| 250 | 5300 | 2200 | 2260 | 6200 |
| 280 | 6300 | 2200 | 2050 | 7500 |
| 315 | 6800 | 2290 | 2200 | 10750 |

Fa₀ : Permissible maximum axial load

Fr : Radial force acting on the shaft

Fr₀ : Permissible maximum radial load at the end of the shaft



Fr_{max} : Permissible maximum radial load at the shaft end

Permissible load calculations are based on a bearing life of L_{h10} 20,000 hours according to ISO 281.

Axial Loads

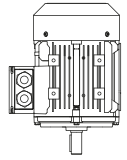
VERTICAL MOUNTING - Shaft Down - Permissible Axial Loads
Mounting Positions IM: V1, V5, V15, V17, V18

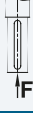
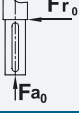
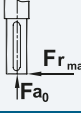

| Frame Size | Push | | | Pull |
|-----------------------------|---|---|---|---|
| | Fr = 0 | Fr = Fr ₀ | Fr = Fr _{max} | Fr = 0 |
| |  |  |  |  |
| 2 Poles 3000 rpm | Fa₀ [N] | Fa₀ [N] | Fa₀ [N] | Fa₀ [N] |
| 63 | 110 | 110 | 110 | 210 |
| 71 | 130 | 130 | 130 | 235 |
| 80 | 220 | 220 | 220 | 385 |
| 90 | 250 | 250 | 250 | 375 |
| 100 | 330 | 330 | 330 | 535 |
| 112 | 340 | 340 | 340 | 520 |
| 132 | 490 | 550 | 550 | 680 |
| 160 | 2600 | 1550 | 1500 | 1500 |
| 180 | 3070 | 1850 | 1750 | 1700 |
| 200 | 3550 | 2300 | 2300 | 2315 |
| 225 | 4250 | 2680 | 2670 | 2630 |
| 250 | 5200 | 3200 | 3280 | 3100 |
| 280 | 6000 | 3900 | 3900 | 2750 |
| 315 | 7320 | 4370 | 4350 | 2825 |
| 4 Poles 1500 rpm | Fa₀ [N] | Fa₀ [N] | Fa₀ [N] | Fa₀ [N] |
| 63 | 120 | 110 | 120 | 300 |
| 71 | 130 | 130 | 130 | 340 |
| 80 | 220 | 220 | 220 | 540 |
| 90 | 260 | 260 | 260 | 545 |
| 100 | 380 | 370 | 370 | 760 |
| 112 | 410 | 400 | 400 | 740 |
| 132 | 580 | 570 | 570 | 1040 |
| 160 | 3500 | 1910 | 1840 | 2100 |
| 180 | 4000 | 2300 | 2170 | 2450 |
| 200 | 4250 | 2870 | 2850 | 2200 |
| 225 | 5000 | 3350 | 3380 | 3740 |
| 250 | 6200 | 4200 | 4000 | 4440 |
| 280 | 8900 | 4850 | 4850 | 4600 |
| 315 | 10900 | 6950 | 6500 | 3900 |
| 6 Poles 1000 rpm | Fa₀ [N] | Fa₀ [N] | Fa₀ [N] | Fa₀ [N] |
| 71 | 130 | 130 | 130 | 415 |
| 80 | 220 | 220 | 220 | 675 |
| 90 | 250 | 250 | 250 | 700 |
| 100 | 360 | 360 | 360 | 960 |
| 112 | 390 | 390 | 390 | 930 |
| 132 | 560 | 560 | 560 | 1310 |
| 160 | 3100 | 2130 | 2120 | 2650 |
| 180 | 3600 | 2600 | 2490 | 3030 |
| 200 | 5000 | 3260 | 3300 | 4000 |
| 225 | 5550 | 3710 | 3810 | 4650 |
| 250 | 6200 | 4510 | 4550 | 5500 |
| 280 | 7500 | 5300 | 5200 | 5750 |
| 315 | 12800 | 7400 | 7800 | 5500 |

Fa₀ : Permissible maximum axial load

Fr : Radial force acting on the shaft

Fr₀ : Permissible maximum radial load at the end of the shaft

Fr_{max} : Permissible maximum radial load at the shaft end

Permissible load calculations are based on a bearing life of Lh10 20,000 hours according to ISO 281.

Ex-Proof Motorlar Ürün Tip Kodu Gösterimi

4 **ZL** **160** **M** **4** **E** **PD** **BA** **162**

| | | |
|-----|--------|--|
| 4 | -----> | <p>Motor Efficiency Classes: 2: IE2 3: IE3 4: IE4</p> |
| ZL | -----> | <p>Basic Motor Types: TG : Cast iron housing ATEX Zone 1-21 motors ZL : Aluminum housing ATEX Zone 2-22 motors ZG : Cast iron housing ATEX Zone 2-22 motors</p> |
| 160 | -----> | <p>Frame Size: 63, 71, 80, 90, 100, 112, 132, 160, 180, 200, 225, 250, 280, 315 Height of the Shaft axis from feet base of motor (mm)</p> |
| M | -----> | <p>Housing Length S : Short M: Medium L : Long</p> |
| 4 | -----> | <p>Number of Poles 2 : 2 Poles 3000 rpm 4 : 4 Poles 1500 rpm 6 : 6 Poles 1000 rpm</p> |
| E | -----> | <p>Core Length: A, B, C, D, E, F, G</p> |
| PD | -----> | <p>Construction Types / Flange Types PD : B3 Foot Mounted FA : B5 Flange FC : B14 Flange FS : Special Flange PA : B35 PC : B34 PS : Foot mounted with special flange Y0..Y9 : With Flange for gearbox connection PX : Foot mounted without drive end shield XX : Without foot and drive end shield Z0-Z9 : Foot mounted Yılmaz type</p> |
| BA | -----> | <p>Electrical Specifications AA..ZZ Voltage, Frequency and Electrical features</p> <p>1st digit: Voltage and Frequency A : 230/400V 50Hz B : 400/690V 50Hz C : 240/415V 50Hz D : 415/720V 50Hz E : 230/400V 60Hz F : 400/690V 60Hz G : 220V 60Hz H : 290/500V 50Hz I : 220/380V 60Hz J : 380/660V 60Hz</p> <p>2nd digit: Additional Electrical features 0: Standard motor, basic version A: Motors with thermistor C: Motors with thermal switch K: Motors with thermistor and anti-condensation heater</p> |
| 162 | -----> | <p>Additional Motor Features 162 : IP66 (All EX motors have a minimum of IP66 protection.)</p> |

**ZONE 2-22
EX MOTORS**



EFF/IE2 Motors

Zone 2-22 Ex-Proof Motors Electrical Characteristics

II 3G Ex ec IIC T4 Gc
II 3D Ex tc IIIC (T120°C ~ T140°C) Dc

400V 50Hz 3000 rpm

Duty Cycle : S1 (Continuous Operation)
Insulation Class : F (155°C)



| Voltage (V) | Type | Rated Values | | | | | | | | Starting Values | | Break Down Torque | Moment of Inertia | B3 Motor Weight | Sound Pressure Level |
|-------------|----------|--------------|-------|---------|--------|--------------|---------------------|------|------|--------------------------------|--------------------------------|-------------------|-------------------|-----------------|----------------------|
| | | Power | Speed | Current | Torque | Power Factor | Efficiency % η | | | Current | Torque | | | | |
| | | kW | rpm | A | Nm | Cos ϕ | 4/4 | 3/4 | 1/2 | I _A /I _N | M _A /M _N | | | | |
| 230/400 | ZL063M2A | 0,18 | 2800 | 0,50 | 0,61 | 0,77 | 67,5 | 66,0 | 62,0 | 4,5 | 2,9 | 3,0 | 0,00012 | 3,80 | 51 |
| | ZL063M2B | 0,25 | 2800 | 0,67 | 0,85 | 0,78 | 69,0 | 68,0 | 63,5 | 4,5 | 2,9 | 3,0 | 0,00015 | 4,00 | 51 |
| | ZL071M2A | 0,37 | 2790 | 0,90 | 1,26 | 0,80 | 74,2 | 74,5 | 72,5 | 5,0 | 2,5 | 2,8 | 0,00031 | 5,70 | 54 |
| | ZL071M2B | 0,55 | 2790 | 1,27 | 1,88 | 0,82 | 75,8 | 77,0 | 76,0 | 5,0 | 2,8 | 2,9 | 0,00037 | 6,20 | 54 |

400V 50Hz 1500 rpm

Duty Cycle : S1 (Continuous Operation)
Insulation Class : F (155°C)



| Voltage (V) | Type | Rated Values | | | | | | | | Starting Values | | Break Down Torque | Moment of Inertia | B3 Motor Weight | Sound Pressure Level |
|-------------|----------|--------------|-------|---------|--------|--------------|---------------------|------|------|--------------------------------|--------------------------------|-------------------|-------------------|-----------------|----------------------|
| | | Power | Speed | Current | Torque | Power Factor | Efficiency % η | | | Current | Torque | | | | |
| | | kW | rpm | A | Nm | Cos ϕ | 4/4 | 3/4 | 1/2 | I _A /I _N | M _A /M _N | | | | |
| 230/400 | ZL063M4B | 0,12 | 1400 | 0,42 | 0,82 | 0,70 | 60,1 | 60,5 | 54,5 | 3,0 | 2,1 | 2,3 | 0,00018 | 4,00 | 42 |
| | ZL063M4C | 0,18 | 1400 | 0,56 | 1,23 | 0,71 | 64,7 | 65,8 | 61,5 | 3,0 | 2,1 | 2,3 | 0,00022 | 4,40 | 42 |
| | ZL071M4B | 0,25 | 1425 | 0,71 | 1,68 | 0,69 | 74,0 | 73,5 | 70,5 | 4,4 | 2,0 | 3,0 | 0,00067 | 6,30 | 46 |
| | ZL071M4C | 0,37 | 1425 | 1,00 | 2,47 | 0,70 | 76,1 | 75,5 | 71,5 | 4,6 | 2,0 | 3,0 | 0,00082 | 7,00 | 46 |
| | ZL080M4B | 0,55 | 1440 | 1,45 | 3,65 | 0,71 | 77,1 | 76,7 | 75,0 | 5,2 | 2,0 | 3,0 | 0,00175 | 9,70 | 50 |

400V 50Hz 1000 rpm

Duty Cycle : S1 (Continuous Operation)
Insulation Class : F (155°C)



| Voltage (V) | Type | Rated Values | | | | | | | | Starting Values | | Break Down Torque | Moment of Inertia | B3 Motor Weight | Sound Pressure Level |
|-------------|---------|--------------|-------|---------|--------|--------------|---------------------|------|------|--------------------------------|--------------------------------|-------------------|-------------------|-----------------|----------------------|
| | | Power | Speed | Current | Torque | Power Factor | Efficiency % η | | | Current | Torque | | | | |
| | | kW | rpm | A | Nm | Cos ϕ | 4/4 | 3/4 | 1/2 | I _A /I _N | M _A /M _N | | | | |
| 230/400 | ZL71M6B | 0,18 | 920 | 0,60 | 1,87 | 0,67 | 64,5 | 63,0 | 57,0 | 3,2 | 1,9 | 2,3 | 0,00076 | 6,10 | 42 |
| | ZL71M6C | 0,25 | 920 | 0,78 | 2,59 | 0,69 | 66,5 | 66,0 | 61,0 | 3,3 | 1,9 | 2,3 | 0,00096 | 6,70 | 42 |
| | ZL80M6A | 0,37 | 925 | 1,08 | 3,82 | 0,69 | 71,4 | 71,5 | 70,0 | 4,0 | 2,0 | 2,6 | 0,00176 | 9,10 | 45 |
| | ZL80M6B | 0,55 | 932 | 1,50 | 5,64 | 0,72 | 73,5 | 74,0 | 71,0 | 4,2 | 2,1 | 2,6 | 0,00202 | 9,80 | 45 |

**ZONE 2-22
EX MOTORS**



EFFIE3 Motors



Zone 2-22 Ex-Proof Motors Electrical Characteristics

II 3G Ex ec IIC T4
Gc II 3D Ex tc IIIC (T120°C ~ T140°C) Dc

400V 50Hz 3000 rpm

Duty Cycle : S1 (Continuous Operation)
Insulation Class : F (155°C)



| Voltage (V) | Type | Rated Values | | | | | | | Starting Values | | Break Down Torque | Moment of Inertia | B3 Motor Weight | Sound Pressure Level | |
|-------------|-----------|--------------|-------|---------|--------|--------------|---------------------|------|-----------------|--------------------------------|--------------------------------|--------------------------------|------------------|----------------------|--------|
| | | Power | Speed | Current | Torque | Power Factor | Efficiency % η | | | Current | | | | | Torque |
| | | kW | rpm | A | Nm | Cos ϕ | 4/4 | 3/4 | 1/2 | I _A /I _N | M _A /M _N | M _K /M _N | kgm ² | kg | dB(A) |
| 230/400 | 3ZL063M2A | 0,18 | 2805 | 0,48 | 0,61 | 0,77 | 70,0 | 68,5 | 62,8 | 4,5 | 3,0 | 3,1 | 0,00012 | 4,00 | 51 |
| | 3ZL063M2B | 0,25 | 2805 | 0,65 | 0,85 | 0,79 | 71,0 | 69,7 | 64,2 | 4,6 | 3,0 | 3,1 | 0,00015 | 4,20 | 51 |
| | 3ZL071M2B | 0,37 | 2830 | 0,84 | 1,25 | 0,82 | 76,6 | 77,0 | 75,0 | 6,0 | 2,8 | 3,0 | 0,00037 | 6,30 | 53 |
| | 3ZL071M2C | 0,55 | 2830 | 1,19 | 1,86 | 0,84 | 79,4 | 80,2 | 78,8 | 6,1 | 2,9 | 3,3 | 0,00046 | 7,00 | 53 |
| | 3ZL080M2B | 0,75 | 2880 | 1,59 | 2,49 | 0,84 | 80,7 | 82,0 | 81,5 | 6,7 | 3,0 | 3,6 | 0,00103 | 9,60 | 54 |
| | 3ZL080M2C | 1,10 | 2880 | 2,26 | 3,64 | 0,85 | 82,7 | 83,0 | 82,4 | 6,8 | 3,1 | 3,8 | 0,00124 | 10,9 | 54 |
| | 3ZL090S2B | 1,50 | 2900 | 2,97 | 4,94 | 0,86 | 84,8 | 85,4 | 84,2 | 7,6 | 3,1 | 3,9 | 0,00178 | 15,2 | 59 |
| | 3ZL090L2C | 2,20 | 2900 | 4,25 | 7,24 | 0,87 | 85,9 | 86,8 | 86,1 | 7,2 | 3,0 | 3,8 | 0,00221 | 17,5 | 59 |
| | 3ZL100L2C | 3,00 | 2910 | 5,58 | 9,85 | 0,89 | 87,1 | 87,6 | 86,9 | 7,9 | 3,0 | 4,1 | 0,00450 | 23,8 | 62 |
| 400/690 | 3ZL112M2C | 4,00 | 2915 | 7,28 | 13,1 | 0,90 | 88,1 | 88,8 | 88,2 | 7,5 | 2,6 | 3,9 | 0,00618 | 29,4 | 65 |
| | 3ZL132S2B | 5,50 | 2945 | 9,90 | 17,8 | 0,90 | 89,2 | 89,0 | 88,6 | 8,9 | 2,9 | 3,9 | 0,01732 | 45,7 | 67 |
| | 3ZL132S2C | 7,50 | 2945 | 13,2 | 24,3 | 0,91 | 90,1 | 90,5 | 89,7 | 8,4 | 2,6 | 4,0 | 0,02104 | 52,0 | 67 |
| | 3ZL160M2B | 11,0 | 2950 | 19,7 | 35,6 | 0,88 | 91,2 | 91,0 | 90,5 | 8,5 | 2,6 | 3,9 | 0,03318 | 79,7 | 69 |
| | 3ZL160M2C | 15,0 | 2950 | 26,5 | 48,6 | 0,89 | 91,9 | 92,1 | 91,6 | 8,9 | 3,1 | 4,2 | 0,03913 | 87,8 | 69 |
| | 3ZL160L2D | 18,5 | 2945 | 31,7 | 60,0 | 0,91 | 92,4 | 92,7 | 92,3 | 8,9 | 3,1 | 4,2 | 0,04409 | 95,2 | 69 |
| | 3ZL180M2B | 22,0 | 2957 | 38,1 | 71,1 | 0,90 | 92,7 | 92,9 | 92,0 | 8,6 | 3,1 | 3,9 | 0,06299 | 131 | 70 |
| | 3ZL200L2B | 30,0 | 2965 | 52,0 | 96,6 | 0,89 | 93,6 | 93,8 | 93,6 | 8,6 | 3,2 | 3,5 | 0,16168 | 181 | 72 |
| | 3ZL200L2C | 37,0 | 2965 | 63,3 | 119 | 0,90 | 93,7 | 94,1 | 93,8 | 8,6 | 3,2 | 3,4 | 0,17458 | 191 | 72 |
| | 3ZG225M2C | 45,0 | 2970 | 76,8 | 145 | 0,90 | 94,0 | 94,4 | 94,2 | 8,6 | 3,3 | 3,1 | 0,25353 | 335 | 74 |
| | 3ZG250M2C | 55,0 | 2970 | 93,3 | 177 | 0,90 | 94,4 | 94,8 | 94,5 | 8,6 | 3,3 | 3,4 | 0,38000 | 425 | 75 |

Zone 2-22 Ex-Proof Motors Electrical Characteristics

II 3G Ex ec IIC T4 Gc
II 3D Ex tc IIIC (T120°C ~ T140°C) Dc

400V 50Hz 1500 rpm

Duty Cycle : S1 (Continuous Operation)
Insulation Class : F (155°C)



| Voltage (V) | Type | Rated Values | | | | | | | Starting Values | | Break Down Torque | Moment of Inertia | B3 Motor Weight | Sound Pressure Level | |
|-------------|-----------|--------------|-------|---------|--------|--------------|---------------------|------|-----------------|--------------------------------|-------------------|-------------------|-----------------|----------------------|--------------------------------|
| | | Power | Speed | Current | Torque | Power Factor | Efficiency % η | | | Current | | | | | Torque |
| | | kW | rpm | A | Nm | Cos ϕ | 4/4 | 3/4 | 1/2 | I _A /I _N | | | | | M _A /M _N |
| 230/400 | 3ZL063M4B | 0,12 | 1405 | 0,37 | 0,82 | 0,70 | 66,0 | 64,9 | 58,2 | 3,7 | 2,3 | 2,7 | 0,00018 | 4,10 | 42 |
| | 3ZL063M4C | 0,18 | 1405 | 0,52 | 1,22 | 0,71 | 69,9 | 68,8 | 63,6 | 3,8 | 2,3 | 2,8 | 0,00022 | 4,50 | 42 |
| | 3ZL071M4C | 0,25 | 1435 | 0,67 | 1,66 | 0,71 | 76,0 | 75,4 | 71,5 | 5,4 | 2,1 | 2,8 | 0,00082 | 7,10 | 45 |
| | 3ZL071M4D | 0,37 | 1435 | 0,97 | 2,46 | 0,70 | 78,5 | 78,2 | 75,0 | 5,5 | 2,2 | 2,9 | 0,00093 | 7,80 | 45 |
| | 3ZL080M4C | 0,55 | 1450 | 1,34 | 3,62 | 0,73 | 80,8 | 80,4 | 77,0 | 5,9 | 2,1 | 3,0 | 0,00200 | 10,5 | 50 |
| | 3ZL080M4D | 0,75 | 1450 | 1,77 | 4,94 | 0,74 | 82,5 | 82,3 | 80,0 | 6,2 | 2,5 | 3,1 | 0,00227 | 11,6 | 50 |
| | 3ZL090S4C | 1,10 | 1450 | 2,51 | 7,25 | 0,75 | 84,5 | 84,3 | 82,0 | 7,0 | 2,6 | 3,4 | 0,00355 | 16,3 | 51 |
| | 3ZL090L4D | 1,50 | 1445 | 3,30 | 9,91 | 0,77 | 85,3 | 85,2 | 83,0 | 7,2 | 2,8 | 3,4 | 0,00411 | 18,0 | 51 |
| | 3ZL100L4C | 2,20 | 1450 | 4,65 | 14,5 | 0,79 | 86,7 | 87,2 | 86,0 | 7,2 | 2,8 | 3,6 | 0,00775 | 24,4 | 53 |
| | 3ZL100L4D | 3,00 | 1450 | 6,26 | 19,8 | 0,79 | 87,7 | 88,0 | 87,0 | 7,2 | 2,8 | 3,6 | 0,00888 | 27,0 | 53 |
| 400/690 | 3ZL112M4D | 4,00 | 1460 | 8,05 | 26,2 | 0,81 | 88,6 | 88,4 | 87,5 | 7,4 | 2,8 | 3,8 | 0,01437 | 32,6 | 58 |
| | 3ZL132S4C | 5,50 | 1465 | 10,9 | 36,0 | 0,81 | 89,6 | 90,2 | 90,0 | 7,0 | 3,0 | 3,3 | 0,03059 | 53,4 | 61 |
| | 3ZL132M4D | 7,50 | 1465 | 14,8 | 48,9 | 0,81 | 90,4 | 90,4 | 89,4 | 7,8 | 3,2 | 3,4 | 0,03418 | 56,6 | 61 |
| | 3ZL160M4C | 11,0 | 1465 | 21,0 | 71,7 | 0,83 | 91,5 | 92,1 | 91,7 | 7,6 | 2,8 | 3,3 | 0,07011 | 89,2 | 63 |
| | 3ZL160L4E | 15,0 | 1465 | 28,7 | 97,8 | 0,82 | 92,1 | 92,4 | 91,9 | 7,8 | 2,8 | 3,5 | 0,08579 | 97,5 | 63 |
| | 3ZL180M4C | 18,5 | 1475 | 35,0 | 120 | 0,82 | 92,6 | 93,2 | 92,9 | 7,7 | 3,0 | 3,3 | 0,12901 | 128 | 64 |
| | 3ZL180L4D | 22,0 | 1470 | 41,4 | 143 | 0,82 | 93,0 | 93,7 | 93,7 | 8,0 | 3,0 | 3,4 | 0,14667 | 141 | 64 |
| | 3ZL200L4D | 30,0 | 1475 | 54,5 | 194 | 0,85 | 93,6 | 94,1 | 94,0 | 8,0 | 3,0 | 3,4 | 0,28413 | 193 | 65 |
| | 3ZG225S4C | 37,0 | 1478 | 65,7 | 239 | 0,87 | 93,9 | 94,5 | 94,5 | 8,3 | 3,2 | 3,3 | 0,38229 | 320 | 66 |
| | 3ZG225M4D | 45,0 | 1477 | 80,0 | 291 | 0,86 | 94,2 | 94,7 | 94,7 | 8,6 | 3,3 | 3,2 | 0,44100 | 350 | 67 |
| 3ZG250M4D | 55,0 | 1482 | 95,3 | 354 | 0,88 | 94,6 | 95,1 | 95,2 | 8,7 | 3,3 | 3,2 | 0,73000 | 460 | 68 | |

Zone 2-22 Ex-Proof Motors Electrical Characteristics

II 3G Ex ec IIC T4 Gc
II 3D Ex tc IIIC (T120°C ~ T140°C) Dc

400V 50Hz 1000 rpm

Duty Cycle : S1 (Continuous Operation)
Insulation Class : F (155°C)



| Voltage (V) | Type | Rated Values | | | | | | | | | Starting Values | | Break Down Torque | Moment of Inertia | B3 Motor Weight | Sound Pressure Level |
|-------------|-----------|--------------|-------|---------|--------|--------------|---------------------|------|------|--------------------------------|--------------------------------|--------------------------------|-------------------|-------------------|-----------------|----------------------|
| | | Power | Speed | Current | Torque | Power Factor | Efficiency % η | | | Current | Torque | | | | | |
| | | kW | rpm | A | Nm | Cos ϕ | 4/4 | 3/4 | 1/2 | I _A /I _N | M _A /M _N | M _K /M _N | | | | |
| 230/400 | 3ZL071M6C | 0,18 | 930 | 0,55 | 1,85 | 0,69 | 68,0 | 67,4 | 62,6 | 3,6 | 2,0 | 2,4 | 0,00096 | 6,80 | 41 | |
| | 3ZL071M6D | 0,25 | 930 | 0,77 | 2,57 | 0,67 | 70,0 | 69,7 | 66,0 | 3,6 | 2,2 | 2,5 | 0,00116 | 7,50 | 41 | |
| | 3ZL080M6B | 0,37 | 930 | 1,03 | 3,80 | 0,70 | 74,0 | 73,8 | 70,0 | 4,4 | 2,1 | 2,6 | 0,00202 | 9,90 | 43 | |
| | 3ZL080M6C | 0,55 | 935 | 1,47 | 5,62 | 0,70 | 77,2 | 77,3 | 74,4 | 4,3 | 2,2 | 2,7 | 0,00228 | 11,0 | 43 | |
| | 3ZL090S6B | 0,75 | 945 | 1,96 | 7,58 | 0,70 | 78,9 | 79,2 | 77,6 | 4,7 | 2,2 | 2,7 | 0,00354 | 16,0 | 46 | |
| | 3ZL090L6C | 1,10 | 940 | 2,75 | 11,2 | 0,71 | 81,0 | 80,8 | 79,4 | 5,0 | 2,2 | 2,7 | 0,00428 | 16,8 | 46 | |
| | 3ZL100L6B | 1,50 | 955 | 3,50 | 15,0 | 0,75 | 82,5 | 82,7 | 81,4 | 5,3 | 2,1 | 2,8 | 0,00821 | 22,5 | 50 | |
| | 3ZL112M6B | 2,20 | 960 | 4,95 | 21,9 | 0,76 | 84,3 | 84,5 | 83,5 | 5,5 | 2,2 | 3,0 | 0,01319 | 29,6 | 56 | |
| 400/690 | 3ZL132S6B | 3,00 | 970 | 6,55 | 29,4 | 0,77 | 85,6 | 85,5 | 84,5 | 6,2 | 2,1 | 3,0 | 0,03051 | 46,7 | 58 | |
| | 3ZL132M6C | 4,00 | 970 | 8,52 | 39,4 | 0,78 | 86,8 | 87,0 | 85,5 | 6,2 | 2,2 | 2,9 | 0,03493 | 50,9 | 58 | |
| | 3ZL132M6D | 5,50 | 965 | 11,6 | 54,4 | 0,78 | 88,0 | 88,9 | 88,5 | 6,2 | 2,2 | 2,8 | 0,03934 | 57,3 | 58 | |
| | 3ZL160M6D | 7,50 | 972 | 15,6 | 73,7 | 0,78 | 89,1 | 89,4 | 88,4 | 6,3 | 2,6 | 3,0 | 0,07870 | 96,0 | 61 | |
| | 3ZL160L6E | 11,0 | 972 | 23,1 | 108 | 0,76 | 90,3 | 90,9 | 90,5 | 6,6 | 2,9 | 3,1 | 0,08580 | 104 | 62 | |
| | 3ZL180L6E | 15,0 | 975 | 30,8 | 147 | 0,77 | 91,2 | 91,6 | 91,0 | 6,7 | 2,9 | 3,1 | 0,15264 | 141 | 63 | |
| | 3ZL200L6C | 18,5 | 977 | 36,4 | 181 | 0,80 | 91,7 | 91,8 | 91,8 | 6,1 | 2,6 | 2,6 | 0,36100 | 164 | 64 | |
| | 3ZL200L6D | 22,0 | 978 | 42,5 | 215 | 0,81 | 92,2 | 92,9 | 93,0 | 6,2 | 2,6 | 2,6 | 0,39355 | 180 | 64 | |
| | 3ZG225S6C | 30,0 | 985 | 57,6 | 291 | 0,81 | 92,9 | 92,9 | 92,6 | 6,6 | 2,9 | 2,7 | 0,60000 | 340 | 65 | |
| | 3ZG250M6C | 37,0 | 988 | 68,8 | 358 | 0,83 | 93,4 | 93,6 | 93,5 | 7,3 | 2,9 | 2,8 | 0,82000 | 435 | 65 | |
| | 3ZG280S6B | 45,0 | 989 | 83,5 | 435 | 0,83 | 93,7 | 93,9 | 93,2 | 6,8 | 2,9 | 2,8 | 1,45000 | 590 | 65 | |
| | 3ZG280M6C | 55,0 | 989 | 102 | 531 | 0,83 | 94,1 | 94,4 | 93,5 | 6,9 | 2,9 | 2,8 | 1,65000 | 620 | 65 | |

**ZONE 2-22
EX MOTORS**



Motors

Zone 2-22 Ex-Proof Motors Electrical Characteristics

II 3G Ex ec IIC T4 Gc
II 3D Ex tc IIIC (T120°C ~ T140°C) Dc

400V 50Hz 3000 rpm

Duty Cycle : S1 (Continuous Operation)
Insulation Class : F (155°C)



| Voltage (V) | Type | Rated Values | | | | | | | | | Starting Values | | Brake Down Torque | Moment of Inertia | B3 Motor Weight | Sound Pressure Level |
|-------------|-----------|--------------|-------|---------|--------|--------------|---------------------|------|------|--------------------------------|--------------------------------|-----|-------------------|-------------------|-----------------|----------------------|
| | | Power | Speed | Current | Torque | Power Factor | Efficiency % η | | | Current | Torque | | | | | |
| | | kW | d/d | A | Nm | Cos ϕ | 4/4 | 3/4 | 1/2 | I _A /I _N | M _A /M _N | | | | | |
| 230/400 | 4ZL071M2B | 0,37 | 2825 | 0,83 | 1,25 | 0,82 | 78,1 | 78,3 | 76,5 | 5,7 | 2,8 | 3,2 | 0,00037 | 6,50 | 58 | |
| | 4ZL071M2C | 0,55 | 2825 | 1,17 | 1,86 | 0,83 | 81,5 | 81,9 | 79,5 | 6,2 | 2,9 | 3,5 | 0,00046 | 7,50 | 58 | |
| | 4ZL080M2C | 0,75 | 2875 | 1,56 | 2,49 | 0,83 | 83,5 | 84,0 | 81,0 | 6,8 | 2,9 | 3,5 | 0,00124 | 11,0 | 59 | |
| | 4ZL080M2D | 1,10 | 2880 | 2,19 | 3,65 | 0,85 | 85,2 | 85,5 | 84,9 | 7,5 | 2,9 | 3,7 | 0,00135 | 12,0 | 59 | |
| | 4ZL090S2C | 1,50 | 2900 | 2,95 | 4,94 | 0,85 | 86,5 | 86,9 | 85,7 | 7,8 | 2,9 | 3,7 | 0,00221 | 17,2 | 64 | |
| | 4ZL090L2D | 2,20 | 2900 | 4,20 | 7,24 | 0,86 | 88,0 | 88,5 | 87,6 | 8,2 | 3,0 | 3,8 | 0,00234 | 20,0 | 64 | |
| | 4ZL100L2D | 3,00 | 2910 | 5,50 | 9,85 | 0,88 | 89,1 | 89,5 | 88,5 | 8,5 | 3,0 | 4,0 | 0,00503 | 25,9 | 67 | |
| 400/690 | 4ZL112M2D | 4,00 | 2940 | 7,30 | 13,0 | 0,88 | 90,0 | 90,3 | 89,7 | 8,7 | 3,0 | 4,2 | 0,00734 | 32,2 | 70 | |
| | 4ZL132S2C | 5,50 | 2945 | 9,60 | 17,8 | 0,91 | 90,9 | 90,9 | 90,0 | 8,9 | 3,2 | 4,2 | 0,02104 | 52,5 | 72 | |
| | 4ZL132S2D | 7,50 | 2945 | 13,0 | 24,5 | 0,91 | 91,7 | 92,2 | 91,8 | 8,5 | 3,2 | 4,2 | 0,02290 | 55,6 | 72 | |
| | 4ZL160M2C | 11,0 | 2950 | 18,9 | 35,6 | 0,91 | 92,6 | 92,7 | 91,2 | 8,5 | 3,3 | 4,3 | 0,03913 | 89,0 | 74 | |
| | 4ZL160M2D | 15,0 | 2950 | 25,6 | 48,6 | 0,91 | 93,3 | 93,6 | 92,8 | 8,5 | 3,3 | 4,3 | 0,04409 | 96,8 | 74 | |
| | 4ZL160L2E | 18,5 | 2955 | 31,4 | 59,8 | 0,91 | 93,7 | 93,8 | 92,9 | 8,7 | 3,2 | 4,3 | 0,05000 | 114 | 74 | |
| | 4ZL180M2C | 22,0 | 2960 | 37,2 | 71,1 | 0,91 | 94,0 | 94,4 | 93,5 | 8,9 | 3,0 | 4,0 | 0,07000 | 158 | 74 | |
| | 4ZL200L2C | 30,0 | 2970 | 51,0 | 96,5 | 0,90 | 94,5 | 94,7 | 94,0 | 8,3 | 3,2 | 3,7 | 0,17500 | 215 | 74 | |
| | 4ZL200L2D | 37,0 | 2970 | 63,3 | 120 | 0,89 | 94,8 | 95,0 | 94,2 | 8,3 | 3,2 | 4,0 | 0,20000 | 235 | 74 | |
| | 4ZG225M2D | 45,0 | 2975 | 76,0 | 145 | 0,90 | 95,0 | 95,2 | 94,9 | 9,0 | 3,4 | 4,2 | 0,29000 | 355 | 74 | |
| | 4ZG250M2D | 55,0 | 2975 | 92,6 | 177 | 0,90 | 95,3 | 95,5 | 94,9 | 8,2 | 3,4 | 3,7 | 0,52000 | 445 | 74 | |
| | 4ZG280S2C | 75,0 | 2982 | 126 | 240 | 0,90 | 95,6 | 95,6 | 95,2 | 7,7 | 2,7 | 3,2 | 0,98000 | 620 | 76 | |
| | 4ZG280M2D | 90,0 | 2985 | 151 | 288 | 0,90 | 95,8 | 95,9 | 95,0 | 7,7 | 2,8 | 3,5 | 1,10000 | 640 | 77 | |
| | 4ZG315S2C | 110 | 2985 | 184 | 352 | 0,90 | 96,0 | 96,0 | 95,7 | 7,8 | 3,1 | 4,0 | 1,60000 | 1110 | 77 | |
| | 4ZG315M2D | 132 | 2986 | 220 | 422 | 0,90 | 96,2 | 96,3 | 96,0 | 8,0 | 3,1 | 4,0 | 2,00000 | 1070 | 77 | |
| | 4ZG315L2E | 160 | 2986 | 267 | 512 | 0,90 | 96,3 | 96,5 | 96,0 | 8,0 | 3,2 | 4,0 | 2,20000 | 1230 | 78 | |
| | 4ZG315L2F | 200 | 2987 | 332 | 639 | 0,90 | 96,5 | 96,7 | 96,2 | 8,1 | 3,2 | 4,0 | 2,70000 | 1340 | 78 | |

Zone 2-22 Ex-Proof Motors Electrical Characteristics

II 3G Ex ec IIC T4 Gc
II 3D Ex tc IIIC (T120°C ~ T140°C) Dc

400V 50Hz 1500 rpm

Duty Cycle : S1 (Continuous Operation)
Insulation Class : F (155°C)



| Voltage (V) | Type | Rated Values | | | | | | | | Starting Values | | Break Down Torque | Moment of Inertia | B3 Motor Weight | Sound Pressure Level |
|-------------|------------|--------------|-------|---------|--------|--------------|---------------------|------|------|--------------------------------|--------------------------------|-------------------|-------------------|-----------------|----------------------|
| | | Power | Speed | Current | Torque | Power Factor | Efficiency % η | | | Current | Torque | | | | |
| | | kW | rpm | A | Nm | Cos ϕ | 4/4 | 3/4 | 1/2 | I _A /I _N | M _A /M _N | | | | |
| 400 / 690 | 4ZL132S4D | 5,50 | 1470 | 11,1 | 35,7 | 0,78 | 91,9 | 91,8 | 90,6 | 7,7 | 3,8 | 3,7 | 0,03418 | 56,7 | 61 |
| | 4ZL132M4F* | 7,50 | 1470 | 14,6 | 48,7 | 0,80 | 92,6 | 92,7 | 91,5 | 7,7 | 3,8 | 4,0 | 0,04316 | 72,8 | 62 |
| | 4ZL160M4E | 11,0 | 1470 | 21,0 | 71,5 | 0,81 | 93,3 | 93,5 | 93,3 | 7,7 | 3,0 | 3,6 | 0,08600 | 99,5 | 64 |
| | 4ZL160L4F | 15,0 | 1475 | 28,9 | 97,5 | 0,80 | 93,9 | 94,1 | 93,8 | 8,7 | 3,7 | 4,3 | 0,12000 | 112 | 64 |
| | 4ZL180M4D | 18,5 | 1475 | 34,6 | 120 | 0,82 | 94,2 | 94,4 | 94,0 | 8,0 | 3,1 | 3,5 | 0,14700 | 142 | 64 |
| | 4ZL180L4E | 22,0 | 1475 | 41,0 | 142 | 0,82 | 94,5 | 94,7 | 94,2 | 8,2 | 3,2 | 3,8 | 0,17000 | 168 | 64 |
| | 4ZG200L4E | 30,0 | 1480 | 53,0 | 194 | 0,86 | 94,9 | 95,3 | 95,2 | 8,3 | 3,3 | 3,8 | 0,35000 | 235 | 64 |
| | 4ZG225S4D | 37,0 | 1480 | 65,0 | 239 | 0,86 | 95,2 | 95,7 | 95,0 | 8,1 | 3,3 | 3,3 | 0,44100 | 350 | 70 |
| | 4ZG225M4E | 45,0 | 1480 | 79,2 | 290 | 0,86 | 95,4 | 95,6 | 95,6 | 8,2 | 3,5 | 3,3 | 0,52000 | 370 | 70 |
| | 4ZG250M4E | 55,0 | 1485 | 94,3 | 354 | 0,88 | 95,7 | 96,0 | 96,0 | 8,5 | 3,3 | 3,4 | 1,05000 | 490 | 70 |
| | 4ZG280S4D | 75,0 | 1487 | 127 | 482 | 0,89 | 96,0 | 96,3 | 96,2 | 8,7 | 3,0 | 3,2 | 1,50000 | 670 | 70 |
| | 4ZG280M4E | 90,0 | 1488 | 152 | 578 | 0,89 | 96,1 | 96,3 | 96,3 | 8,9 | 3,1 | 3,2 | 1,95000 | 720 | 71 |
| | 4ZG315S4D | 110 | 1491 | 187 | 705 | 0,88 | 96,3 | 96,5 | 96,0 | 8,9 | 2,8 | 3,3 | 2,80000 | 1200 | 73 |
| | 4ZG315M4E | 132 | 1492 | 225 | 845 | 0,88 | 96,4 | 96,7 | 96,2 | 8,9 | 2,9 | 3,3 | 3,30000 | 1270 | 73 |
| | 4ZG315L4F | 160 | 1492 | 272 | 1024 | 0,88 | 96,6 | 96,9 | 96,5 | 8,9 | 3,1 | 3,4 | 4,40000 | 1370 | 76 |
| | 4ZG315L4G | 200 | 1492 | 339 | 1280 | 0,88 | 96,7 | 97,0 | 96,6 | 8,8 | 3,3 | 3,5 | 5,20000 | 1520 | 76 |

Motors marked with * do not have a symmetrical housing structure.

Zone 2-22 Ex-Proof Motors Electrical Characteristics

II 3G Ex ec IIC T4 Gc
II 3D Ex tc IIIC (T120°C ~ T140°C) Dc

400V 50Hz 1000 rpm

Duty Cycle : S1 (Continuous Operation)
Insulation Class : F (155°C)



| Voltage (V) | Type | Rated Values | | | | | | | | Starting Values | | Break Down Torque | Moment of Inertia | B3 Motor Weight | Sound Pressure Level |
|-------------|-----------|--------------|-------|---------|--------|--------------|---------------------|------|------|--------------------------------|--------------------------------|-------------------|-------------------|-----------------|----------------------|
| | | Power | Speed | Current | Torque | Power Factor | Efficiency % η | | | Current | Torque | | | | |
| | | kW | rpm | A | Nm | Cos ϕ | 4/4 | 3/4 | 1/2 | I _A /I _N | M _A /M _N | | | | |
| 400/690 | 4ZG315S6C | 75,0 | 994 | 133 | 721 | 0,85 | 95,4 | 95,5 | 95,2 | 8,80 | 2,80 | 3,50 | 3,50000 | 1215 | 67 |
| | 4ZG315M6D | 90,0 | 994 | 160 | 865 | 0,85 | 95,6 | 95,7 | 95,4 | 8,80 | 2,80 | 3,70 | 3,80000 | 1250 | 67 |
| | 4ZG315L6E | 110 | 995 | 193 | 1056 | 0,86 | 95,8 | 96,1 | 95,7 | 8,60 | 2,80 | 3,70 | 4,50000 | 1280 | 68 |
| | 4ZG315L6F | 132 | 995 | 231 | 1267 | 0,86 | 96,0 | 96,2 | 95,8 | 8,50 | 2,80 | 3,70 | 5,20000 | 1350 | 68 |
| | 4ZG315L6G | 160 | 995 | 280 | 1536 | 0,86 | 96,2 | 96,4 | 96,3 | 7,70 | 2,90 | 3,80 | 5,55000 | 1446 | 70 |

**ZONE 2-22
EX MOTORS**



Dimensions

Zone 2-22 Ex-Proof Motors

B3 Construction Type

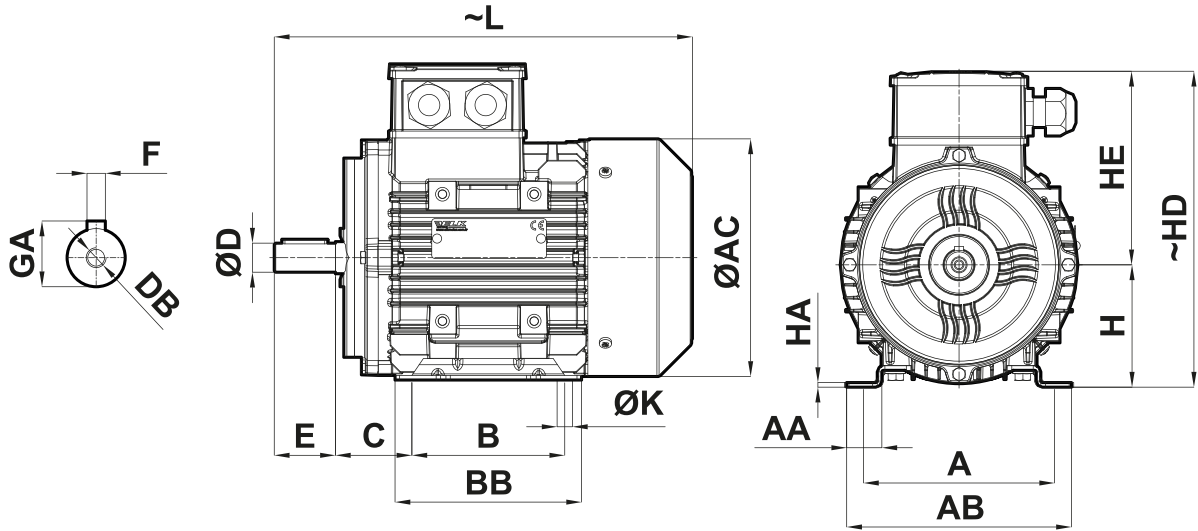

| Frame Size | Efficiency Class | Number of Poles | D ^[1] | E | L | AC | H ^[2] | HE | HD | F | GA | DB | C | ØK | B | BB | HA | AA | A | AB |
|---------------------|------------------|-----------------|------------------|-----|------|-----|------------------|-------|-------|----|------|-----|-----|------|-----|-----|----|-----|-----|-----|
| 063M | IE2/IE3 | 2-4-6-8 | 11 | 23 | 213 | 119 | 63 | 101 | 164 | 4 | 12,5 | M4 | 40 | 7 | 80 | 104 | 3 | 18 | 100 | 115 |
| 071M | IE2/IE3/IE4 | 2-4-6-8 | 14 | 30 | 242 | 137 | 71 | 118 | 189 | 5 | 16 | M5 | 45 | 7 | 90 | 110 | 3 | 19 | 112 | 128 |
| 080M | IE2/IE3/IE4 | 2-4-6-8 | 19 | 40 | 274 | 155 | 80 | 127 | 207 | 6 | 21,5 | M6 | 50 | 10 | 100 | 122 | 3 | 25 | 125 | 148 |
| 090S | IE3/IE4 | 2-4-6-8 | 24 | 50 | 325 | 176 | 90 | 136 | 226 | 8 | 27 | M8 | 56 | 10 | 100 | 151 | 4 | 27 | 140 | 167 |
| 090L | IE3/IE4 | 2-4-6-8 | 24 | 50 | 325 | 176 | 90 | 136 | 226 | 8 | 27 | M8 | 56 | 10 | 125 | 151 | 4 | 27 | 140 | 167 |
| 100L | IE3/IE4 | 2-4-6-8 | 28 | 60 | 369 | 193 | 100 | 149 | 249 | 8 | 31 | M10 | 63 | 12 | 140 | 170 | 4 | 31 | 160 | 191 |
| 112M | IE3/IE4 | 2-4-6-8 | 28 | 60 | 392 | 215 | 112 | 161 | 273 | 8 | 31 | M10 | 70 | 12 | 140 | 177 | 4 | 36 | 190 | 217 |
| 132S | IE3/IE4 | 2-4-6-8 | 38 | 80 | 495 | 257 | 132 | 182 | 314 | 10 | 41 | M12 | 89 | 12 | 140 | 212 | 5 | 34 | 216 | 246 |
| 132M | IE3/IE4 | 2-4-6-8 | 38 | 80 | 495 | 257 | 132 | 182 | 314 | 10 | 41 | M12 | 89 | 12 | 178 | 212 | 5 | 34 | 216 | 246 |
| 132M ^[3] | IE4 | 4 | 38 | 80 | 543 | 257 | 132 | 182 | 314 | 10 | 41 | M12 | 89 | 12 | 178 | 212 | 5 | 34 | 216 | 246 |
| 160M | IE3/IE4 | 2-4-6-8 | 42 | 110 | 605 | 316 | 160 | 226 | 386 | 12 | 45 | M16 | 108 | 14,5 | 210 | 328 | 15 | 65 | 254 | 293 |
| 160L | IE3/IE4 | 2-4-6-8 | 42 | 110 | 605 | 316 | 160 | 226 | 386 | 12 | 45 | M16 | 108 | 14,5 | 254 | 328 | 15 | 65 | 254 | 293 |
| 180M | IE3/IE4 | 2-4-6-8 | 48 | 110 | 696 | 348 | 180 | 242 | 422 | 14 | 51,5 | M16 | 121 | 14,5 | 241 | 319 | 15 | 63 | 279 | 316 |
| 180L | IE3/IE4 | 2-4-6-8 | 48 | 110 | 696 | 348 | 180 | 242 | 422 | 14 | 51,5 | M16 | 121 | 14,5 | 279 | 319 | 15 | 63 | 279 | 316 |
| 200M | IE3/IE4 | 2-4-6-8 | 55 | 110 | 737 | 396 | 200 | 294 | 494 | 16 | 59 | M20 | 133 | 18,5 | 267 | 350 | 20 | 76 | 318 | 372 |
| 200L | IE3/IE4 | 2-4-6-8 | 55 | 110 | 737 | 396 | 200 | 294 | 494 | 16 | 59 | M20 | 133 | 18,5 | 305 | 350 | 20 | 76 | 318 | 372 |
| 225S | IE3/IE4 | 2 | 55 | 110 | 800 | 438 | 225 | 311,5 | 536,5 | 16 | 59 | M20 | 149 | 18,5 | 286 | 360 | 20 | 90 | 356 | 417 |
| | | 4-6-8 | 60 | 140 | 830 | | | | | 18 | 64 | | | | | | | | | |
| 225M | IE3/IE4 | 2 | 55 | 110 | 800 | 438 | 225 | 311,5 | 536,5 | 16 | 59 | M20 | 149 | 18,5 | 311 | 360 | 20 | 90 | 356 | 417 |
| | | 4-6-8 | 60 | 140 | 830 | | | | | 18 | 64 | | | | | | | | | |
| 250S | IE3/IE4 | 2 | 60 | 140 | 896 | 481 | 250 | 337 | 587 | 18 | 64 | M20 | 168 | 24 | 311 | 433 | 32 | 105 | 406 | 475 |
| | | 4-6-8 | 65 | | | | | | | 18 | 69 | | | | | | | | | |
| 250M | IE3/IE4 | 2 | 60 | 140 | 896 | 481 | 250 | 337 | 587 | 18 | 64 | M20 | 168 | 24 | 349 | 433 | 32 | 105 | 406 | 475 |
| | | 4-6-8 | 65 | | | | | | | 18 | 69 | | | | | | | | | |
| 280S | IE3/IE4 | 2 | 65 | 140 | 1012 | 547 | 280 | 402 | 682 | 18 | 69 | M20 | 190 | 24 | 368 | 500 | 35 | 105 | 457 | 531 |
| | | 4-6-8 | 75 | | | | | | | 20 | 79,5 | | | | | | | | | |
| 280M | IE3/IE4 | 2 | 65 | 140 | 1012 | 547 | 280 | 402 | 682 | 18 | 69 | M20 | 190 | 24 | 419 | 500 | 35 | 105 | 457 | 531 |
| | | 4-6-8 | 75 | | | | | | | 20 | 79,5 | | | | | | | | | |
| 315S | IE3/IE4 | 2 | 65 | 140 | 1242 | 622 | 315 | 499 | 814 | 18 | 69 | M20 | 216 | 28 | 406 | 636 | 33 | 157 | 508 | 626 |
| | | 4-6-8 | 80 | 170 | 1272 | | | | | 22 | 85 | | | | | | | | | |
| 315M | IE3/IE4 | 2 | 65 | 140 | 1242 | 622 | 315 | 499 | 814 | 18 | 69 | M20 | 216 | 28 | 457 | 636 | 33 | 157 | 508 | 626 |
| | | 4-6-8 | 80 | 170 | 1272 | | | | | 22 | 85 | | | | | | | | | |
| 315L | IE3/IE4 | 2 | 65 | 140 | 1389 | 622 | 315 | 499 | 814 | 18 | 69 | M20 | 216 | 28 | 508 | 800 | 35 | 145 | 508 | 623 |
| | | 4-6-8 | 90 | 170 | 1419 | | | | | 25 | 95 | | | | | | | | | |

[1] Tolerance "j6" up063-250 to 28mm, "k6" from 28mm to 48mm, "m6" over 48mm TS EN 50347

[2] Tolerance "-0.5mm" / 280-315 "-1mm" TS EN 50347

[3] Extended motor housing

Zone 2-22 Ex-Proof Motors



B5 - B35 Construction Type

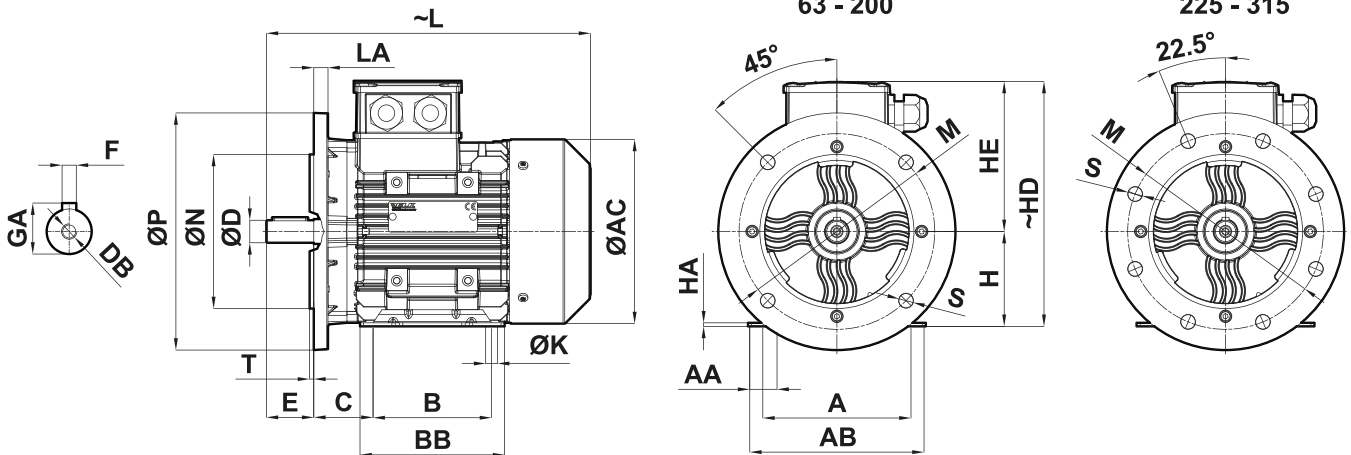

| Frame Size | Efficiency Class | Number of Poles | D ^[1] | E | N ^[2] | P | T | LA | L | AC | S | M | H ^[3] | HE | HD | F | GA | DB | C | ØK | B | BB | HA | AA | A | AB |
|---------------------|------------------|-----------------|------------------|-----|------------------|-----|-----|----|------|-----|------|-----|------------------|-----|-----|----|------|-----|-----|------|-----|-----|----|-----|-----|-----|
| 063M | IE2/IE3 | 2-4-6-8 | 11 | 23 | 95 | 140 | 3 | 8 | 213 | 119 | 10 | 115 | 63 | 97 | 160 | 4 | 12,5 | M4 | 40 | 7 | 80 | 104 | 3 | 18 | 100 | 115 |
| 071M | IE2/IE3/IE4 | 2-4-6-8 | 14 | 30 | 110 | 160 | 3,5 | 8 | 242 | 137 | 10 | 130 | 71 | 112 | 183 | 5 | 16 | M5 | 45 | 7 | 90 | 110 | 3 | 19 | 112 | 128 |
| 080M | IE2/IE3/IE4 | 2-4-6-8 | 19 | 40 | 130 | 200 | 3,5 | 12 | 274 | 155 | 12 | 165 | 80 | 127 | 207 | 6 | 21,5 | M6 | 50 | 10 | 100 | 122 | 3 | 25 | 125 | 148 |
| 090S | IE3/IE4 | 2-4-6-8 | 24 | 50 | 130 | 200 | 3,5 | 12 | 325 | 176 | 12 | 165 | 90 | 136 | 226 | 8 | 27 | M8 | 56 | 10 | 100 | 151 | 4 | 27 | 140 | 167 |
| 090L | IE3/IE4 | 2-4-6-8 | 24 | 50 | 130 | 200 | 3,5 | 12 | 325 | 176 | 12 | 165 | 90 | 136 | 226 | 8 | 27 | M8 | 56 | 10 | 125 | 151 | 4 | 27 | 140 | 167 |
| 100L | IE3/IE4 | 2-4-6-8 | 28 | 60 | 180 | 250 | 4 | 15 | 369 | 193 | 14,5 | 215 | 100 | 148 | 248 | 8 | 31 | M10 | 63 | 12 | 140 | 170 | 4 | 31 | 160 | 191 |
| 112M | IE3/IE4 | 2-4-6-8 | 28 | 60 | 180 | 250 | 4 | 15 | 392 | 215 | 14,5 | 215 | 112 | 161 | 273 | 8 | 31 | M10 | 70 | 12 | 140 | 177 | 4 | 36 | 190 | 217 |
| 132S | IE3/IE4 | 2-4-6-8 | 38 | 80 | 230 | 300 | 4 | 20 | 495 | 257 | 14,5 | 265 | 132 | 180 | 312 | 10 | 41 | M12 | 89 | 12 | 140 | 212 | 5 | 34 | 216 | 246 |
| 132M | IE3/IE4 | 2-4-6-8 | 38 | 80 | 230 | 300 | 4 | 20 | 495 | 257 | 14,5 | 265 | 132 | 180 | 312 | 10 | 41 | M12 | 89 | 12 | 178 | 212 | 5 | 34 | 216 | 246 |
| 132M ^[4] | IE4 | 4 | 38 | 80 | 230 | 300 | 4 | 20 | 543 | 257 | 14,5 | 265 | 132 | 180 | 312 | 10 | 41 | M12 | 89 | 12 | 178 | 212 | 5 | 34 | 216 | 246 |
| 160M | IE3/IE4 | 2-4-6-8 | 42 | 110 | 250 | 350 | 5 | 20 | 605 | 316 | 18,5 | 300 | 160 | 220 | 380 | 12 | 45 | M16 | 108 | 14,5 | 210 | 328 | 15 | 65 | 254 | 293 |
| 160L | IE3/IE4 | 2-4-6-8 | 42 | 110 | 250 | 350 | 5 | 20 | 605 | 316 | 18,5 | 300 | 160 | 220 | 380 | 12 | 45 | M16 | 108 | 14,5 | 254 | 328 | 15 | 65 | 254 | 293 |
| 180M | IE3/IE4 | 2-4-6-8 | 48 | 110 | 250 | 350 | 5 | 14 | 696 | 348 | 18,5 | 300 | 180 | 239 | 419 | 14 | 51,5 | M16 | 121 | 14,5 | 241 | 319 | 15 | 63 | 279 | 316 |
| 180L | IE3/IE4 | 2-4-6-8 | 48 | 110 | 250 | 350 | 5 | 14 | 696 | 348 | 18,5 | 300 | 180 | 239 | 419 | 14 | 51,5 | M16 | 121 | 14,5 | 279 | 319 | 15 | 63 | 279 | 316 |
| 200M | IE3/IE4 | 2-4-6-8 | 55 | 110 | 300 | 400 | 5 | 14 | 737 | 396 | 18,5 | 350 | 200 | 294 | 494 | 16 | 59 | M20 | 133 | 18,5 | 267 | 350 | 20 | 76 | 318 | 372 |
| 200L | IE3/IE4 | 2-4-6-8 | 55 | 110 | 300 | 400 | 5 | 14 | 737 | 396 | 18,5 | 350 | 200 | 294 | 494 | 16 | 59 | M20 | 133 | 18,5 | 305 | 350 | 20 | 76 | 318 | 372 |
| 225S | IE3/IE4 | 2 | 55 | 110 | 350 | 450 | 5 | 20 | 800 | 438 | 18,5 | 400 | 225 | 312 | 537 | 16 | 59 | M20 | 149 | 18,5 | 286 | 360 | 20 | 90 | 356 | 417 |
| | | 4-6-8 | 60 | 140 | | | | | 830 | | | | | | | | | | | | | | | | | |
| 225M | IE3/IE4 | 2 | 55 | 110 | 350 | 450 | 5 | 20 | 800 | 438 | 18,5 | 400 | 225 | 312 | 537 | 16 | 59 | M20 | 149 | 18,5 | 311 | 360 | 20 | 90 | 356 | 417 |
| | | 4-6-8 | 60 | 140 | | | | | 830 | | | | | | | | | | | | | | | | | |
| 250S | IE3/IE4 | 2 | 60 | 140 | 450 | 550 | 5 | 20 | 896 | 481 | 18,5 | 500 | 250 | 337 | 587 | 18 | 64 | M20 | 168 | 24 | 311 | 433 | 32 | 105 | 406 | 475 |
| | | 4-6-8 | 65 | | | | | | | | | | | | | | | | | | | | | | | |
| 250M | IE3/IE4 | 2 | 60 | 140 | 450 | 550 | 5 | 20 | 896 | 481 | 18,5 | 500 | 250 | 337 | 587 | 18 | 64 | M20 | 168 | 24 | 349 | 433 | 32 | 105 | 406 | 475 |
| | | 4-6-8 | 65 | | | | | | | | | | | | | | | | | | | | | | | |
| 280S | IE3/IE4 | 2 | 65 | 140 | 450 | 550 | 5 | 20 | 1012 | 547 | 18,5 | 500 | 280 | 402 | 682 | 18 | 69 | M20 | 190 | 24 | 368 | 500 | 35 | 105 | 457 | 531 |
| | | 4-6-8 | 75 | | | | | | | | | | | | | | | | | | | | | | | |
| 280M | IE3/IE4 | 2 | 65 | 140 | 450 | 550 | 5 | 20 | 1012 | 547 | 18,5 | 500 | 280 | 402 | 682 | 18 | 69 | M20 | 190 | 24 | 419 | 500 | 35 | 105 | 457 | 531 |
| | | 4-6-8 | 75 | | | | | | | | | | | | | | | | | | | | | | | |
| 315S | IE3/IE4 | 2 | 65 | 140 | 550 | 660 | 6 | 25 | 1242 | 622 | 24 | 600 | 315 | 499 | 814 | 18 | 69 | M20 | 216 | 28 | 406 | 636 | 33 | 157 | 508 | 626 |
| | | 4-6-8 | 80 | | | | | | 170 | | | | | | | | | | | | | | | | | |
| 315M | IE3/IE4 | 2 | 65 | 140 | 550 | 660 | 6 | 22 | 1242 | 622 | 24 | 600 | 315 | 499 | 814 | 18 | 69 | M20 | 216 | 28 | 457 | 636 | 33 | 157 | 508 | 626 |
| | | 4-6-8 | 85 | | | | | | 170 | | | | | | | | | | | | | | | | | |
| 315L | IE3/IE4 | 2 | 60 | 140 | 550 | 660 | 6 | 22 | 1389 | 622 | 24 | 600 | 315 | 499 | 814 | 18 | 69 | M20 | 216 | 28 | 508 | 800 | 35 | 145 | 508 | 623 |
| | | 4-6-8 | 90 | | | | | | 170 | | | | | | | | | | | | | | | | | |

[1] Tolerance "j6" up to 28mm, "k6" from 28mm to 48mm, "m6" over 48mm TS EN 50347

[2] Tolerance "j6" up to 250mm, "h6" over 250mm TS EN 50347

[3] Tolerance 063-250 "-0.5mm" / 280-315 "-1mm" TS EN 50347

[4] Extended motor housing □

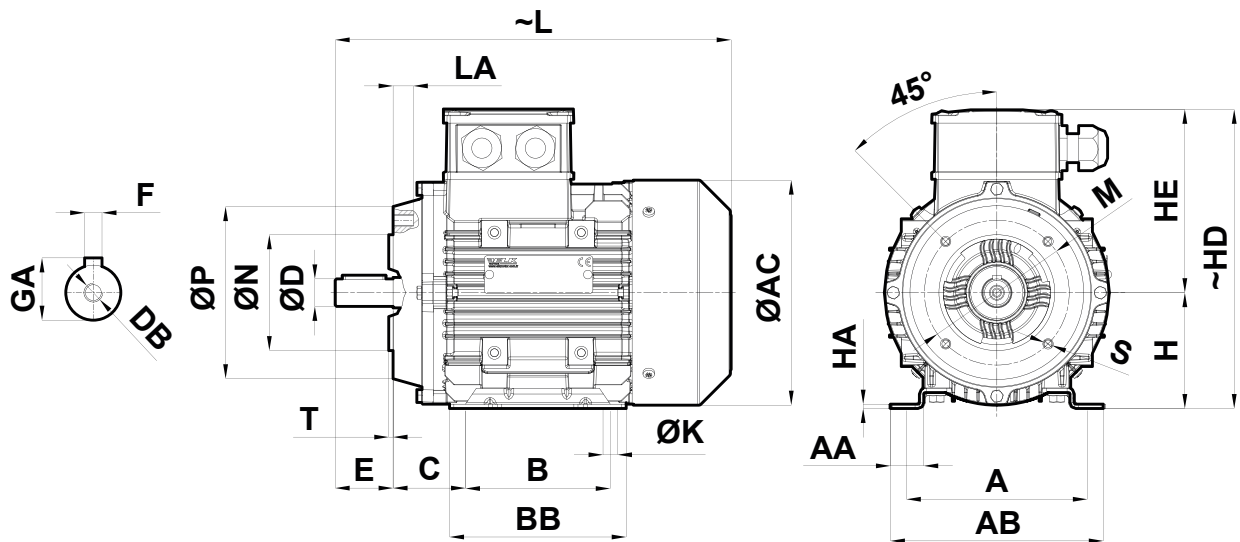

| Frame Size | Efficiency Class | Number of Poles | D ^[1] | N ^[2] | P | E | T | LA | L | AC | S | M | H ^[3] | HE | HD | F | GA | DB | C | ØK | B | BB | HA | AA | A | AB |
|---------------------|------------------|-----------------|------------------|------------------|-----|-----|-----|----|-----|-----|-----|-----|------------------|-----|-----|----|------|-----|-----|------|-----|-----|----|----|-----|-----|
| 063M | IE2/IE3 | 2-4-6-8 | 11 | 60 | 90 | 23 | 2,5 | 10 | 213 | 119 | M5 | 75 | 63 | 101 | 164 | 4 | 12,5 | M4 | 40 | 7 | 80 | 104 | 3 | 18 | 100 | 115 |
| 071M | IE2/IE3/IE4 | 2-4-6-8 | 14 | 70 | 105 | 30 | 2,5 | 12 | 242 | 137 | M6 | 85 | 71 | 118 | 189 | 5 | 16 | M5 | 45 | 7 | 90 | 110 | 3 | 19 | 112 | 128 |
| 080M | IE2/IE3/IE4 | 2-4-6-8 | 19 | 80 | 119 | 40 | 3 | 12 | 274 | 155 | M6 | 100 | 80 | 127 | 207 | 6 | 21,5 | M6 | 50 | 10 | 100 | 122 | 3 | 25 | 125 | 148 |
| 090S | IE3/IE4 | 2-4-6-8 | 24 | 95 | 137 | 50 | 3 | 15 | 325 | 176 | M8 | 115 | 90 | 136 | 226 | 8 | 27 | M8 | 56 | 10 | 100 | 151 | 4 | 27 | 140 | 167 |
| 090L | IE3/IE4 | 2-4-6-8 | 24 | 95 | 137 | 50 | 3 | 15 | 325 | 176 | M8 | 115 | 90 | 136 | 226 | 8 | 27 | M8 | 56 | 10 | 125 | 151 | 4 | 27 | 140 | 167 |
| 100L | IE3/IE4 | 2-4-6-8 | 28 | 110 | 160 | 60 | 3,5 | 17 | 369 | 193 | M8 | 130 | 100 | 149 | 249 | 8 | 31 | M10 | 63 | 12 | 140 | 170 | 4 | 31 | 160 | 191 |
| 112M | IE3/IE4 | 2-4-6-8 | 28 | 110 | 160 | 60 | 3,5 | 17 | 392 | 215 | M8 | 130 | 112 | 161 | 273 | 8 | 31 | M10 | 70 | 12 | 140 | 177 | 4 | 36 | 190 | 217 |
| 132S | IE3/IE4 | 2-4-6-8 | 38 | 130 | 200 | 80 | 3,5 | 20 | 495 | 257 | M10 | 165 | 132 | 182 | 314 | 10 | 41 | M12 | 89 | 12 | 140 | 212 | 5 | 34 | 216 | 246 |
| 132M | IE3/IE4 | 2-4-6-8 | 38 | 130 | 200 | 80 | 3,5 | 20 | 495 | 257 | M10 | 165 | 132 | 182 | 314 | 10 | 41 | M12 | 89 | 12 | 178 | 212 | 5 | 34 | 216 | 246 |
| 132M ^[4] | IE4 | 4 | 38 | 130 | 200 | 80 | 3,5 | 20 | 543 | 257 | M10 | 165 | 132 | 182 | 314 | 10 | 41 | M12 | 89 | 12 | 178 | 212 | 5 | 34 | 216 | 246 |
| 160M | IE3/IE4 | 2-4-6-8 | 42 | 180 | 250 | 110 | 4 | 23 | 605 | 316 | M12 | 215 | 160 | 226 | 386 | 12 | 45 | M16 | 108 | 14,5 | 210 | 323 | 15 | 65 | 254 | 295 |
| 160L | IE3/IE4 | 2-4-6-8 | 42 | 180 | 250 | 110 | 4 | 23 | 605 | 316 | M12 | 215 | 160 | 226 | 386 | 12 | 45 | M16 | 108 | 14,5 | 254 | 323 | 15 | 65 | 254 | 295 |

[1] Tolerance "j6" up to 28mm, "k6" over 28mm TS EN 50347

[2] Tolerance "j6" TS EN 50347

[3] Tolerance "-0.5mm" TS EN 50347

[4] Extended motor housing

Zone 2-22 Ex-Proof Motor Nameplate Example

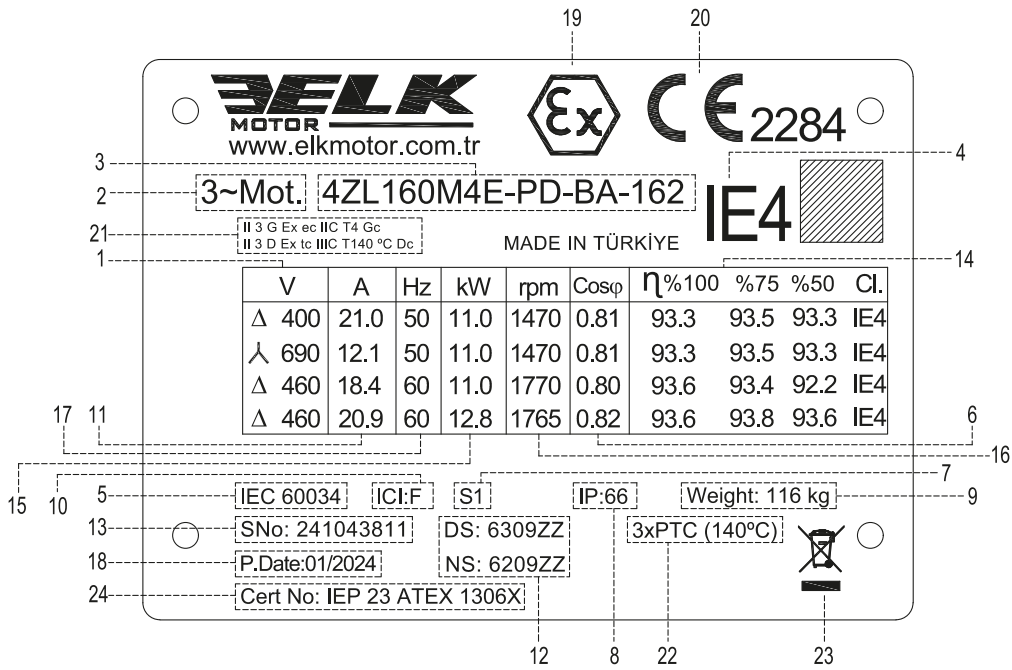

- | | |
|-------------------------------------|-------------------------------|
| 1. Rated Voltage | 13. Serial Number |
| 2. Motor Type: 3 Phase Asynchronous | 14. Efficiency |
| 3. Motor Code | 15. Output Power |
| 4. Efficiency Class | 16. Speed |
| 5. Manufacture Standard | 17. Frequency |
| 6. Power Factor | 18. Production Date |
| 7. Duty Cycle | 19. Ex-Proof Logo |
| 8. Protection Class | 20. CE Mark |
| 9. Motor Weight | 21. ATEX Classification Codes |
| 10. Insulation Class | 22. 3xPTC Thermistor |
| 11. Rated Current | 23. WEEE Symbol |
| 12. Bearing Type | 24. Certificate Number |



The nameplate shows the identification, and the most important technical data. The nameplate also defines the limits of proper usage, and manufacturing year of the motors. The first two digits in the serial number, shows the manufacturing year. For example, 24XXXXXX shows that the product is manufactured in 2024.

Zone 2-22 Exproof Motors Spare Parts

All the standard three phase motors are produced by ELK MOTOR consist of the following main parts;

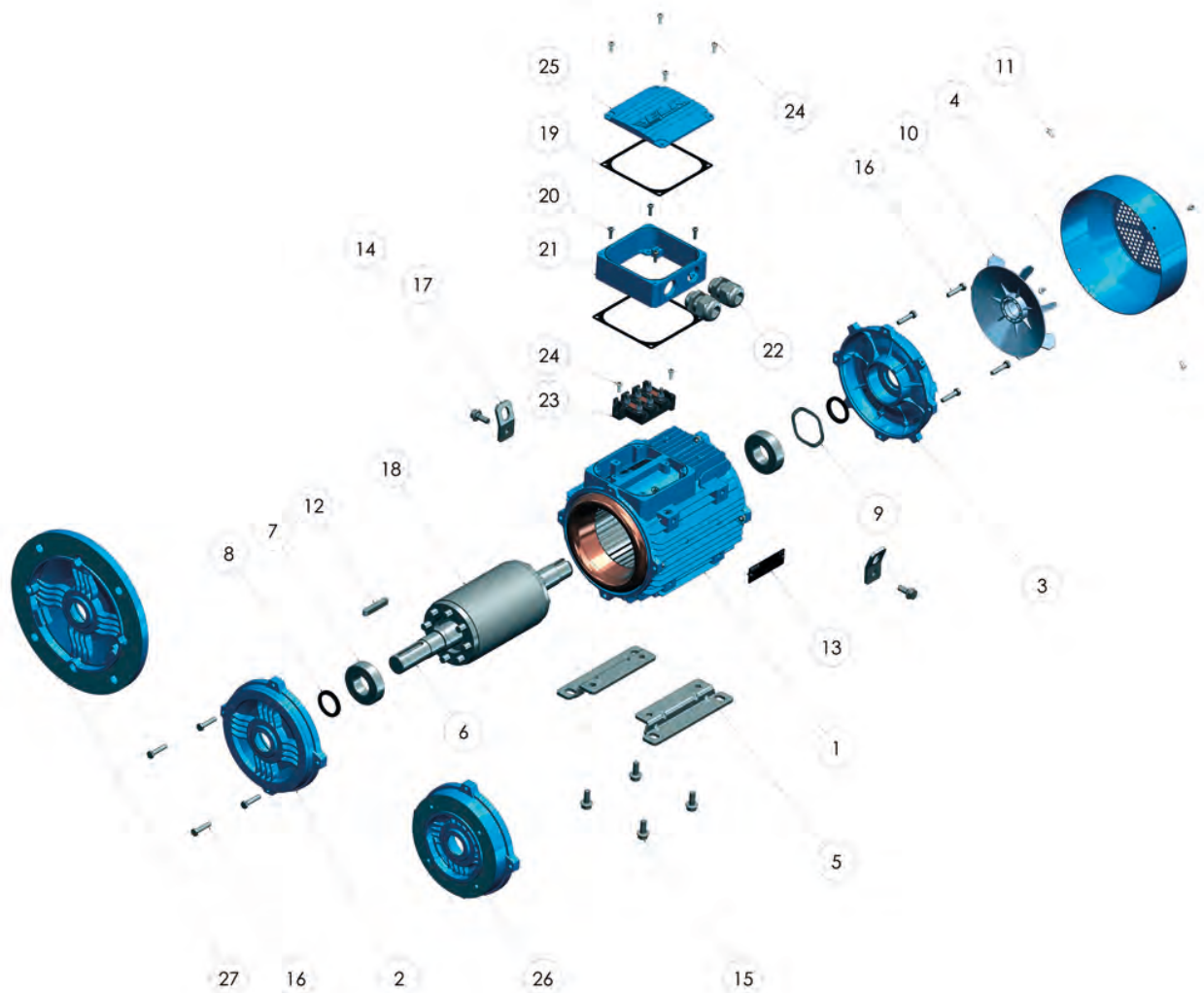

1. Housing

2. End Shield (DE)

3. End Shield (NDE)

4. Fan Cover

5. Mounting Foot

6. Shaft

7. Bearing

8. Shaft Seal

9. Spring Washer

10. Fan

11. Screw

12. Key

13. Nameplate

14. Screw

15. Screw

16. Bolt

17. Lifting Lug

18. Squirrel Cage Rotor

19. Terminal Box Gasket

20. Screw

21. Terminal Box

22. ATEX Cable Gland (Metal)

23. Terminal

24. Screw

25. Terminal Box Cover

26. B14 Flange

27. B5 Flange

While ordering spare parts, the motor serial number, full type designation and product code, as stated on the nameplate, must be specified. For field service, spare parts and additional information, please contact us.

In an Ex-Proof motor, spare parts that protect the internal volume must not be replaced by individuals or organizations without a module E certificate. Replacement of these critical parts should be carried out by authorized companies or manufacturers with the relevant certification.

ACCESSORIES

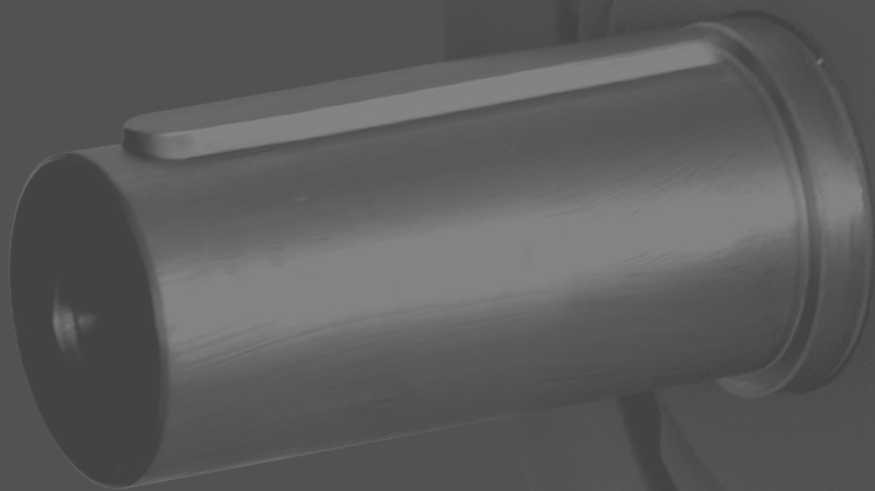

PTC Thermistor and Thermal Switch

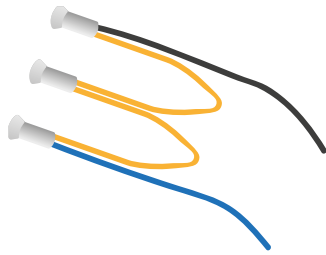

Thermistor

Thermistor (PTC) is a temperature-dependent resistor. Its resistance increases after defined threshold temperature value to signal outside of an over-heating and/or over-loading condition. The thermistor must be evaluated with a proper electronics and/or a VSD with thermistor inputs.

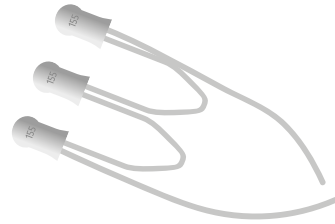

Thermostat

A thermostat (PTO) functions in a way that is fundamentally similar to PTC thermistors; however, unlike PTC thermistors, thermostats provide voltage-free contacts that can be directly used to switch off a circuit, provided the current capacity of the thermostat is not exceeded.

Anti-Condensation Space Heater and Drainage

In environments with high humidity, condensation may occur inside the motor. To prevent this, space heaters are wrapped around the motor windings to maintain a consistent temperature. Additionally, drainage holes are provided in the motor body to prevent water accumulation and mitigate the risk of condensation.

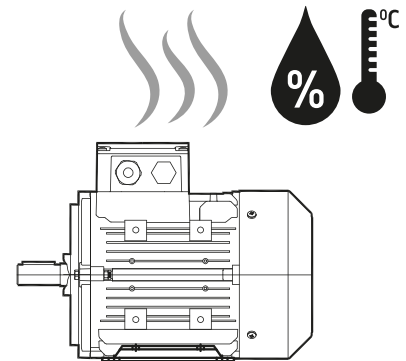

NDE Shaft and Canopy

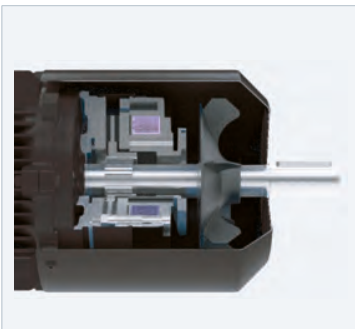

NDE Shaft Extension

Non drive end shaft is used when it is desired to transfer the motor power to a second load or to manually rotate it when the motor is not energized



Canopy

It is used for operation in the outside environment where the motor fan is pointing upwards. This prevents the rainwater from entering the motor housing.

Brake, Hand Release, Separately Driven Fan Encoder and Backstop

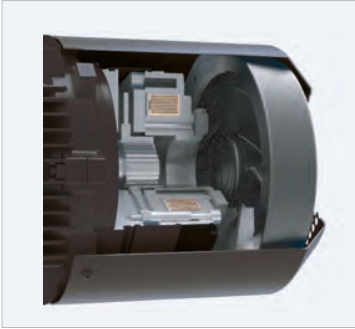

Electromagnetic Brake

For each motor size, we offer a NDE mounted electromagnetic brake option. Brakes with supply voltages of 24V, 230V, and 400V DC, ranging from 5Nm to 1600Nm, are available and can be selected according to the specific needs.

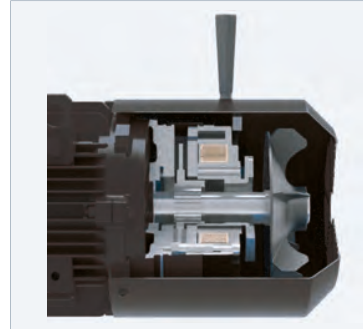

Brake with Hand Release

In case of a power failure or when the brake needs to be released without applying electricity, it is used to release the system by overcoming the braking force through the lever on the brake.

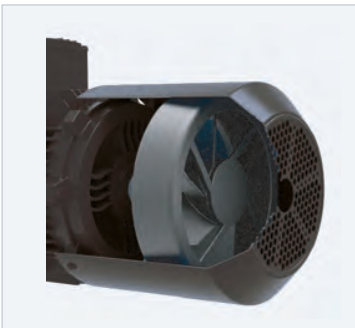

Separately Driven Fan

In applications with variable-speed drives where the motor's speed is reduced, the efficiency of the motor fan's cooling decreases. The required cooling airflow is provided by a force cooling fan connected to the motor casing.

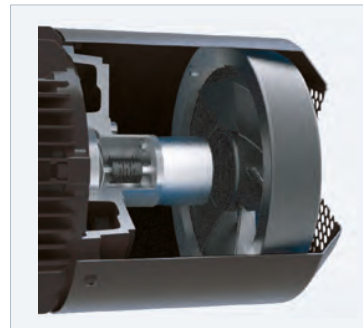

Separately Driven Fan with Encoder

In applications where closed loop speed/torque control is required, a NDE mounted encoder can be used. Since the encoder is mounted on the motor's NDE end-shield, the motor fan cannot be used. Therefore, force cooling fan is also provided for the motor.

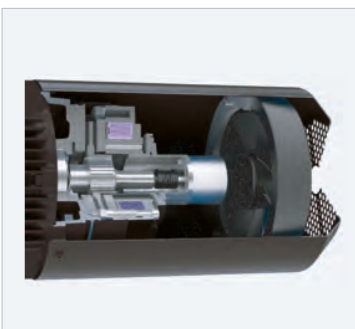

Separately Driven Fan with Brake and Encoder

In applications requiring both braking and synchronous operation, the brake, encoder, and forced fan options are all provided as rear-mounted components on the motor.

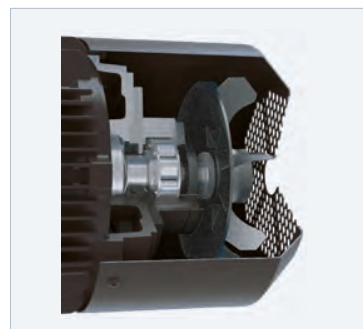

Backstop

Backstop is used in situations where movement is desired in one direction and must be prevented in the opposite direction when the motor stops. The backstop option integrated into the rear motor housing is commonly used.

По вопросам продаж и поддержки обращайтесь:

Алматы (727)345-47-04
Ангарск (3955)60-70-56
Архангельск (8182)63-90-72
Астрахань (8512)99-46-04
Барнаул (3852)73-04-60
Белгород (4722)40-23-64
Благовещенск (4162)22-76-07
Брянск (4832)59-03-52
Владивосток (423)249-28-31
Владикавказ (8672)28-90-48
Владимир (4922)49-43-18
Волгоград (844)278-03-48
Вологда (8172)26-41-59
Воронеж (473)204-51-73
Екатеринбург (343)384-55-89

Иваново (4932)77-34-06
Ижевск (3412)26-03-58
Иркутск (395)279-98-46
Казань (843)206-01-48
Калининград (4012)72-03-81
Калуга (4842)92-23-67
Кемерово (3842)65-04-62
Киров (8332)68-02-04
Коломна (4966)23-41-49
Кострома (4942)77-07-48
Краснодар (861)203-40-90
Красноярск (391)204-63-61
Курск (4712)77-13-04
Курган (3522)50-90-47
Липецк (4742)52-20-81

Магнитогорск (3519)55-03-13
Москва (495)268-04-70
Мурманск (8152)59-64-93
Набережные Челны (8552)20-53-41
Нижний Новгород (831)429-08-12
Новокузнецк (3843)20-46-81
Ноябрьск (3496)41-32-12
Новосибирск (383)227-86-73
Омск (3812)21-46-40
Орел (4862)44-53-42
Оренбург (3532)37-68-04
Пенза (8412)22-31-16
Петрозаводск (8142)55-98-37
Псков (8112)59-10-37
Пермь (342)205-81-47

Ростов-на-Дону (863)308-18-15
Рязань (4912)46-61-64
Самара (846)206-03-16
Санкт-Петербург (812)309-46-40
Саратов (845)249-38-78
Севастополь (8692)22-31-93
Саранск (8342)22-96-24
Симферополь (3652)67-13-56
Смоленск (4812)29-41-54
Сочи (862)225-72-31
Ставрополь (8652)20-65-13
Сургут (3462)77-98-35
Сыктывкар (8212)25-95-17
Тамбов (4752)50-40-97
Тверь (4822)63-31-35

Тольятти (8482)63-91-07
Томск (3822)98-41-53
Тула (4872)33-79-87
Тюмень (3452)66-21-18
Ульяновск (8422)24-23-59
Улан-Удэ (3012)59-97-51
Уфа (347)229-48-12
Хабаровск (4212)92-98-04
Чебоксары (8352)28-53-07
Челябинск (351)202-03-61
Череповец (8202)49-02-64
Чита (3022)38-34-83
Якутск (4112)23-90-97
Ярославль (4852)69-52-93

Россия +7(495)268-04-70

Казахстан +7(727)345-47-04

Беларусь +(375)257-127-884

Узбекистан +998(71)205-18-59

Киргизия +996(312)96-26-47

эл.почта: eko@nt-rt.ru || сайт: <https://elk-motor.nt-rt.ru/>